

High flow rate with minimum installation space:

The AxiTwin 100 – *with counter-rotating impellers in one compact fan.*



Particularly in IT, telecommunications, network technology, and renewable energy, highly integrated electronics require cooling air that safely reaches all components to be cooled inside. In some cases, conventional single fans are too weak, but the installation space for several fans is too small.

With the AxiTwin100, two individual fans connected with an innovative flange work together by **rotating in opposite directions**. This enables the rear fan to convert the residual swirl from the front fan into air flow particularly efficiently which increases efficiency compared to individual solutions. As a result, the solution offers a **high level of efficiency with minimum space requirements**.

ebmpapst

engineering a better life

Technical data

Technology:

- + Completely new design
- + Counterwise rotating impellers
- + 2 independent drives (redundancy)

Material:

- + Housing: Fiberglass-reinforced composite material (PBT)
- + Impeller: Fiberglass-reinforced composite material (PA)
- + Center flange: Die-cast aluminum

Weight:

- + 600g

Approvals:

- + VDE, UL/CSA, CE, CCC

Options:

- + PWM speed control
- + Analogue speed control
- + Speed signal
- + Alarm signal

CONTACT:

(860) 674-1515
sales@us.ebmpapst.com

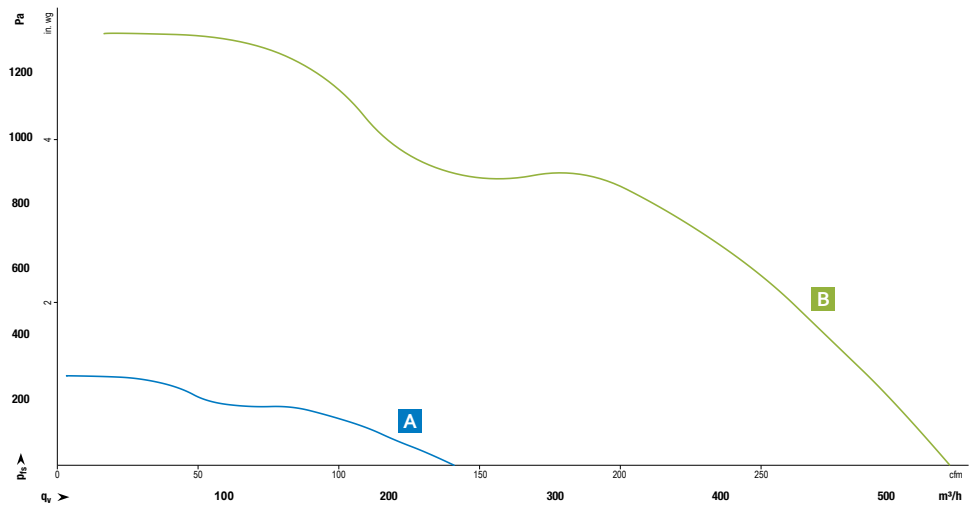
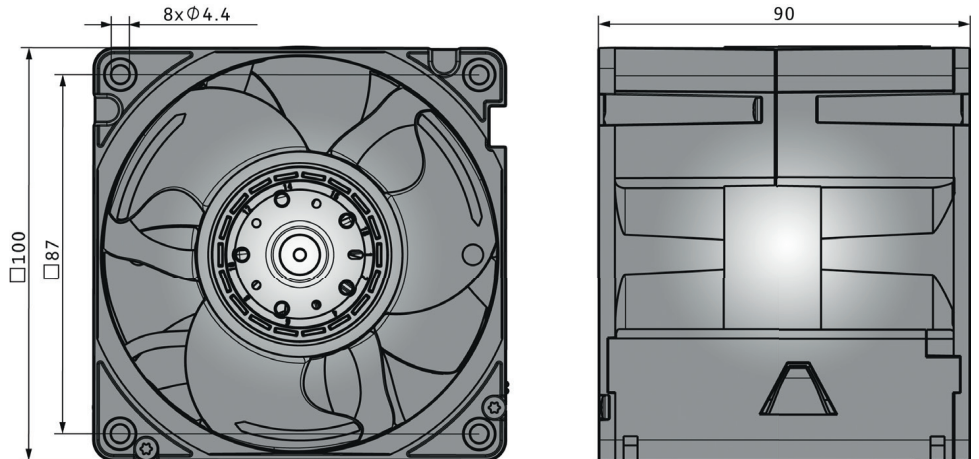

Nominal data

Type	Air flow*		Nominal voltage		Sound power level		Sound pressure*		Sintec sleeve bearings Ball bearings		Power consumption		Nominal Speed stage 1*		Nominal Speed stage 2*		Temperature range	Weight	Service life L10 (40°C) acc. IPC 9591
	m³/h	cfm	VDC ⁻¹	VDC	Bel (A)	db (A)	■ / ■	Watt	Watt	rpm ⁻¹	rpm ⁻¹	°C	g	Hours					
VWE0100TUGCS			48	36...+60													-20...+70	600	
A	40% speed	240	141		7.1	65		22	45		5,000	4,000							142,500
B	100% speed	536	315		9.0	82	■	127	220		11,000	9,000							117,500

Subject to change * At free air flow