

Flexibility that's out of this world. *The resilient AxiACi.*

For the diverse requirements in refrigeration technology, industrial ventilation, and telecom applications.

ebmpapst

engineering a better life





The AxiACi series *for all worlds.*

Harsh environmental conditions, international areas of use, diverse applications. No problem for the AxiACi series.



Up to 2 times the service life of standard AC fans



Up to 83% less power consumption with the same air flow*



Up to 3 dB(A) quieter*



Wide voltage from 90 to 264VAC



Unbeatably compact and lightweight

*Compared with common rival products in size 92.

In use *all over the world.*



The AxiACi series was developed specifically for use in commercial refrigerated cabinets and also demonstrates its high flexibility and efficiency in applications from the fields of control cabinet cooling, industry and telecommunications. Whatever the application, the AxiACi series is designed to withstand the rigors of extreme environments while delivering high levels of flexibility and efficiency.

Manufacturers of refrigerated cabinets in particular benefit from possible operating temperatures down to -40°C (including when starting up), ATEX certification (DIN EN 60 079-7 (Group 2A, T4)) and resistance to salt spray, water jets, and dust (IP65). And of course from the fact that the AxiACi series is also ideally suited for use with natural refrigerants such as ammonia, propane, ethanol cyclohexane, n-butane and others.

Houston, we have an Innovation.

The extremely quiet and highly efficient motor of the AxiACi series has an impressively long service life with reduced service intervals and is the perfect replacement for obsolete AC solutions. The motor, electronics and aerodynamic components are perfectly coordinated.

Low structure-borne noise

Vibrations are generated by the rotary motion of a motor. If these hit the resonant frequency of the application, disturbing sound waves can develop. The motor of the AxiACi was developed to have a very low floor level and low peaks in the acceleration amplitudes. It is therefore optimized to keep structure-borne noise low.

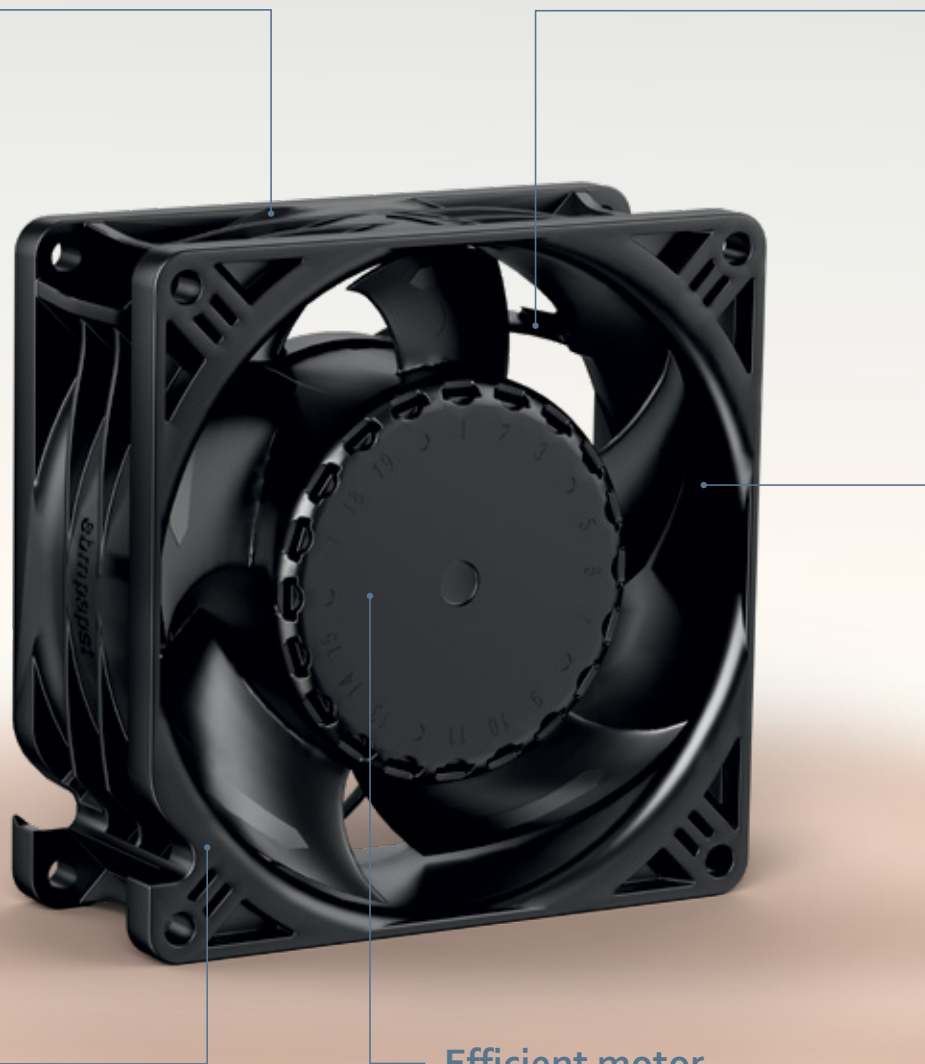

Aerodynamic design

The optimized blade design with winglets and the perfectly designed and tuned fan housing/impeller combination audibly reduce operating noise.

Efficient motor

The GreenTech EC motor runs extremely smoothly and with low vibration. The unbeatably efficient motor technology used ensures particularly quiet operation and low energy consumption.

Optimized guide blades

The guide blades are perfectly matched to the dynamically balanced fan impeller, resulting in less turbulence and a directed air flow. So more power where it counts.

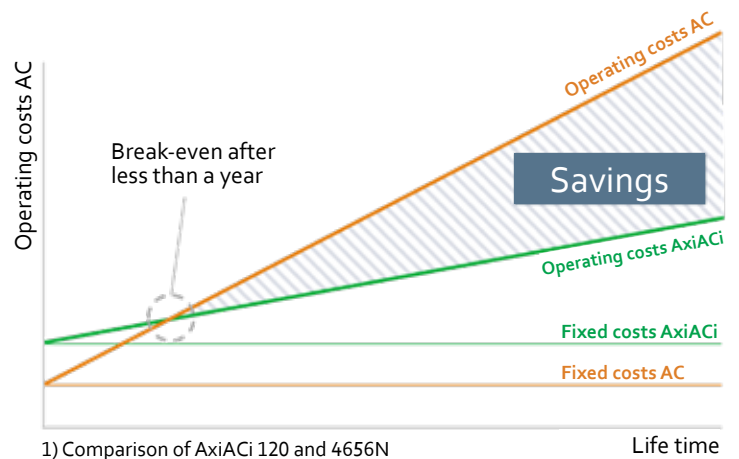

Powerful properties

Approvals:

- + UL507, CSA 22.3, DIN EN 60335-1
CCC, EAC, CE

Voltage range:

- + Wide voltage from 90 to 264VAC

Broad temperature range:

- + from +75 to -40°C

Protected against high humidity of up to 98% (no condensation)

Optional:

- + IP65, DIN EN 60335-2-89, DIN EN 60079-7 Group IIA, T4, salt spray resistance

The AxiACi pays for itself

Thanks to its low energy consumption, it usually pays for itself after months rather than years. With electricity prices rising out of this world, even sooner.*

**Product costs, operating costs and service life are responsible for the total costs over the entire product life cycle. Operating costs depend on electricity prices in the respective country and the operating time. Assuming favorable electricity prices of 0.10 EUR/kWh and 18 hours of operation per day, even with the higher purchase price of the AxiACi 92, the payback period is only 12 months. With rising electricity prices even sooner.*

Stellar levels of power:
the AxiACi series.



AxiACi 92: DC axial compact fan · max. 95 m³/h · □ 92 x 38 mm

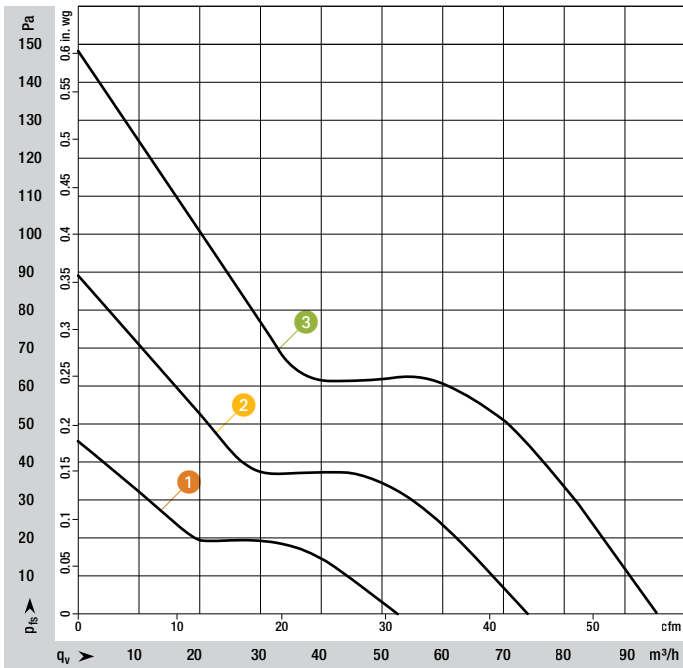

The combination of an aerodynamically optimized impeller and our GreenTech motor delivers huge performance values and greater efficiency.

Description:

- + Newly developed flow geometry
- + New 3-phase motor concept for low structure-borne noise
- + Highly efficient
- + Airflow direction: blowing over struts
- + Direction of rotation: counterclockwise, looking towards rotor
- + Housing material: plastic (PBT)
- + Fan impeller material: plastic (PA)
- + Standard approvals: UL, CSA, VDE, CCC, EAC
- + Various speed versions

Optional (as an environmentally protected version):

- + Salt spray resistance
- + IP65
- + ATEX DIN EN 60079-7
- + DIN EN 60335-2-89 and DIN EN 60335-2-24

Nominal data

Type	Number	Voltage range VAC	Frequency Hz	Power consumption W	Current consumption mA	Speed rpm	Blocking protection □/■	Wires 310mm, AWG24 □/■	max. air volume m ³ /h	max. air volume cfm	Sound pressure free blowing in rubber bands dbA	Temperature range °C	Life time (40°C) ebm-papst standard Hours	UL507 □/■	CSA 22.3 □/■	DIN EN 60335-1 □/■	CCC, EAC, CE □/■	Weight g	Curve
VWCF092DSGGS	8315100281	90-264	50/60	1,3	27	2.500	■	■	53	31,2	26	-40°C - +75°C	65.000	■	■	■	■	235	①
VWCF092DSGHS	8315100282	90-264	50/60	2,1	30	3.500	■	■	74	43,6	38	-40°C - +75°C	65.000	■	■	■	■	235	②
VWCF092DSGJS	8315100283	90-264	50/60	3,4	37	4.500	■	■	95	55,9	51	-40°C - +75°C	65.000	■	■	■	■	235	③

Data sheets are available on request. Subject to technical changes.

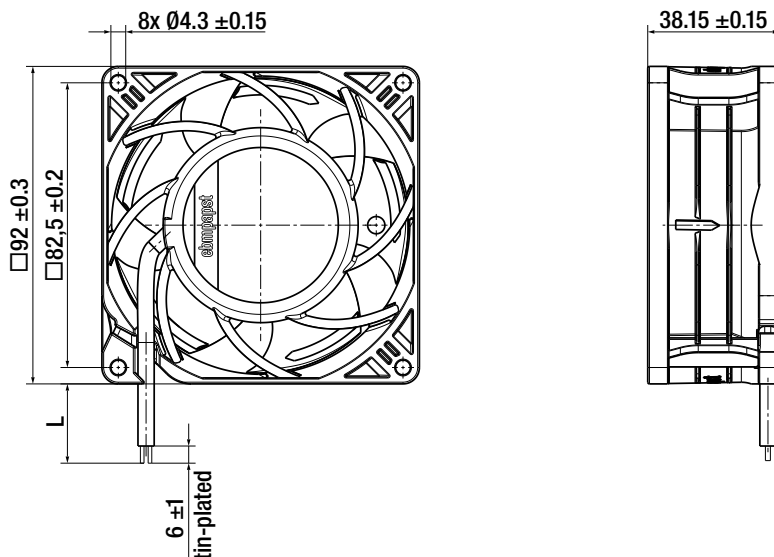



What *Engineering*
a better life means
to us.

Who we are.

With over 20,000 different products, ebm-papst offers the right solution for just about any challenge. As the logical next stage in the development of our highly-efficient GreenTech EC technology, we believe that industrial digitization offers the greatest future prospects for our customers. With GreenIntelligence, we already represent intelligently interconnected complete solutions that are unrivaled worldwide.

Because we are always committed to making each of our innovative hardware and software solutions more powerful, compact, efficient and sustainable than its predecessor, we have evolved over the years into the global technology leader for ventilation and drive technology.

What drives us.

But our consistent pursuit of efficiency and progress has even deeper roots. After all, there is something that excites us even more than our market position. It is the deep awareness that, with our solutions, like **AxiACi**, we are making the lives of many people around the globe more pleasant, safer and thus better. Therefore, the central driving force in all our thoughts and actions is Engineering a better life. It is the reason why it is worthwhile for us to get up every day and do our best.

More about this under ebmpapst.com/betterlife

What you get out of it.

- 1. Technological edge.**
With our EC technology and GreenIntelligence, we combine the highest energy efficiency with the advantages of IoT and digital networking.
- 2. Our sustainable approach.**
We take our responsibility seriously with energy-saving products, environmentally-friendly processes and through social engagement.
- 3. System expertise.**
As experts in advanced motor technology, electronics and aerodynamics, we provide perfect system solutions from a single source.
- 4. The ebm-papst spirit of invention.**
Over 800 engineers and technicians will develop a solution that precisely fits your needs.
- 5. Personal proximity to you.**
Thanks to numerous sales locations worldwide.
- 6. Our standard of quality.**
Our quality management is uncompromising, at every step and in every process.



ebmpapst

engineering a better life

Get in touch with us.

Let's find out how ebm-papst can help to make your company and your solutions even better.

If you have any questions, please contact:

Bernhard Thürmer

Tel.: +49 7724 81 1216

bernhard.thuermer@de.ebmpapst.com

www.ebmpapst.com

ebm-papst

St. Georgen GmbH & Co. KG

Hermann-Papst-Straße 1

78112 St. Georgen

Germany

Phone +49 7724 81-0

Fax +49 7724 81-1309

info2@de.ebmpapst.com