



Operating Instructions

ebm-papst A&NZ Pty Ltd
10 Oxford Road
Laverton North VIC 3026
Australia
Phone: +61 3 9360 6400
Fax: +61 3 9360 6464
sales@ebmpapst.com.au
www.ebmpapst.com.au

CONTENTS

1.	SAFETY REGULATIONS AND NOTES	1
2.	TECHNICAL DATA	2
2.1	Product drawing.....	2
2.2	Ancillary component data	2

1. SAFETY REGULATIONS AND NOTES

Please read these operating instructions carefully before starting to work with the device. Observe the following warnings to prevent malfunctions or physical damage to both property and people.

Product W2E300-CC47-02 is assembled in Australia and incorporates imported product A2E300AC4702.

For product drawing see Chapter 2.1 'Product drawing' of this document and Chapter 2.2 'Ancillary component data' for specifications of sub components.

For safety regulations and information, intended use, technical data, connection and start-up and maintenance, malfunctions, possible causes and remedies refer to operating instructions of A2E300AC4702.

These operating instructions are to be regarded as part of this device. If the device is sold or transferred, the operating instructions must accompany it.

These operating instructions may be duplicated and forwarded for information about potential dangers and their prevention.



Operating Instructions

2. TECHNICAL DATA

2.1 Product drawing

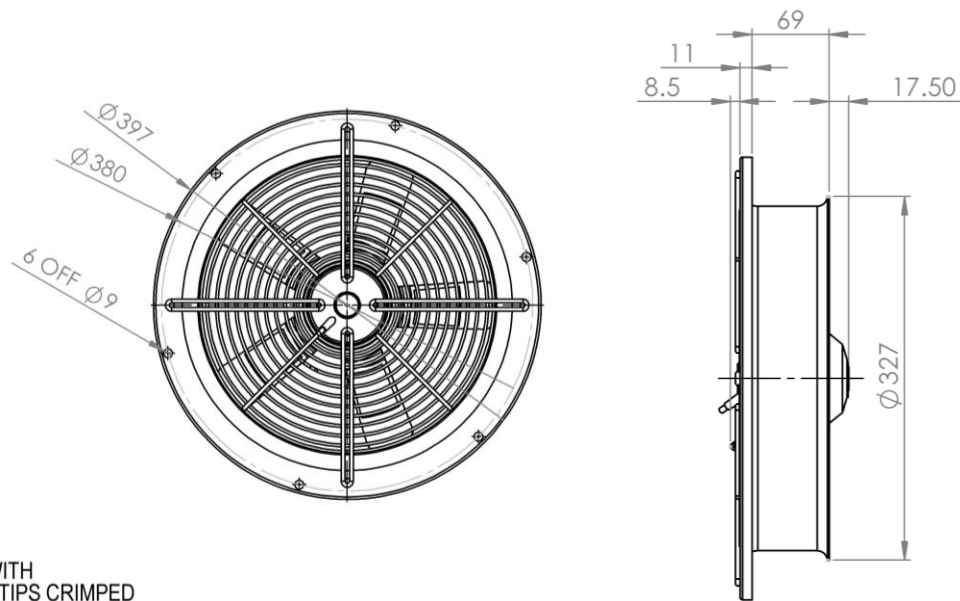

450mm CABLE WITH
4x BRASS LEAD TIPS CRIMPED
NOT SHOWN

AIRFLOW DIRECTION →

All dimensions are in mm

Direction of air flow "A"

Cable

Customer end stripped 85 mm
4x brass lead tips crimped to 6 mm

2.2 Ancillary component data

Weight [kg]	4.60
Material of guard grille	Steel phosphate and coated in black
Material of wall ring	Sheet steel, pre-galvanised and coated in black plastic
Capacitor	5 μ F, S0