



# Operating Instructions

ebm-papst A&NZ Pty Ltd  
10 Oxford Road  
Laverton North VIC 3026  
Australia  
Phone: +61 3 9360 6400  
Fax: +61 3 9360 6464  
[sales@ebmpapst.com.au](mailto:sales@ebmpapst.com.au)  
[www.ebmpapst.com.au](http://www.ebmpapst.com.au)

## CONTENTS

1.	<b>SAFETY REGULATIONS AND NOTES</b> .....	1
2.	<b>TECHNICAL DATA</b> .....	2
2.1	Product drawing.....	2
2.2	Ancillary component data .....	2

## 1. SAFETY REGULATIONS AND NOTES

Please read these operating instructions carefully before starting to work with the device. Observe the following warnings to prevent malfunctions or physical damage to both property and people.

Product W2S130-AA03-63M is assembled in Australia and incorporates imported product W2S130AA0363.

For product drawing see Chapter 2.1 'Product drawing' of this document and Chapter 2.2 'Ancillary component data' for specifications of sub components.

For safety regulations and information, intended use, technical data, connection and start-up and maintenance, malfunctions, possible causes and remedies refer to operating instructions of W2S130AA0363.

These operating instructions are to be regarded as part of this device. If the device is sold or transferred, the operating instructions must accompany it.

These operating instructions may be duplicated and forwarded for information about potential dangers and their prevention.



# Operating Instructions

## 2. TECHNICAL DATA

### 2.1 Product drawing

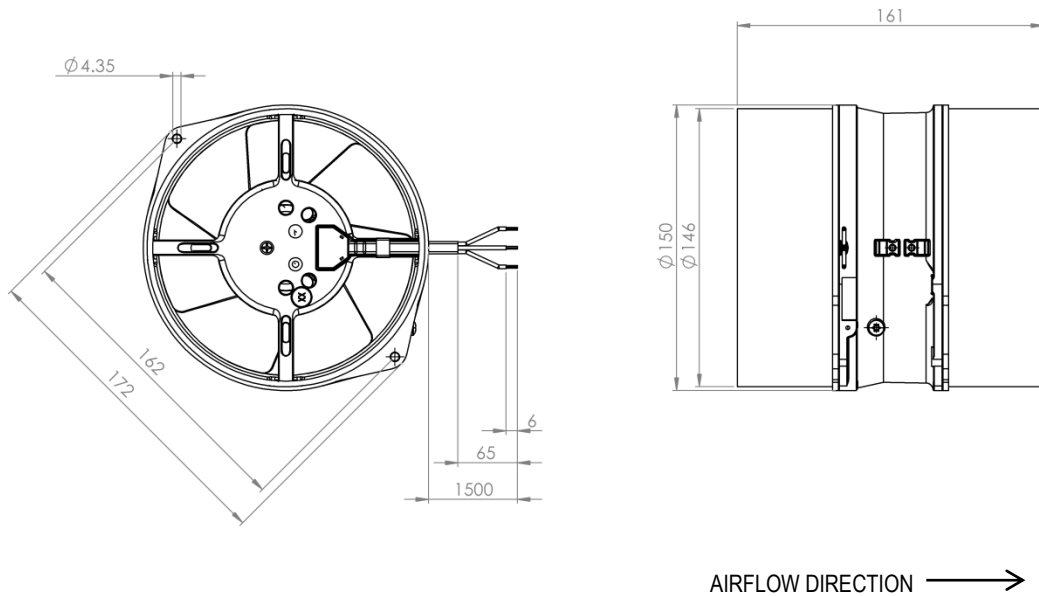

All dimensions are in mm

Direction of air flow “V”

#### Cable

Customer end stripped 65 mm  
3x crimped splices

### 2.2 Ancillary component data

Weight [kg]	1.28
Material of housing spigot	Black ABS