

# RadiPac EC centrifugal fans.

New dimensions in efficiency: sizes 630–1,000

# ebmpapst

The engineer's choice

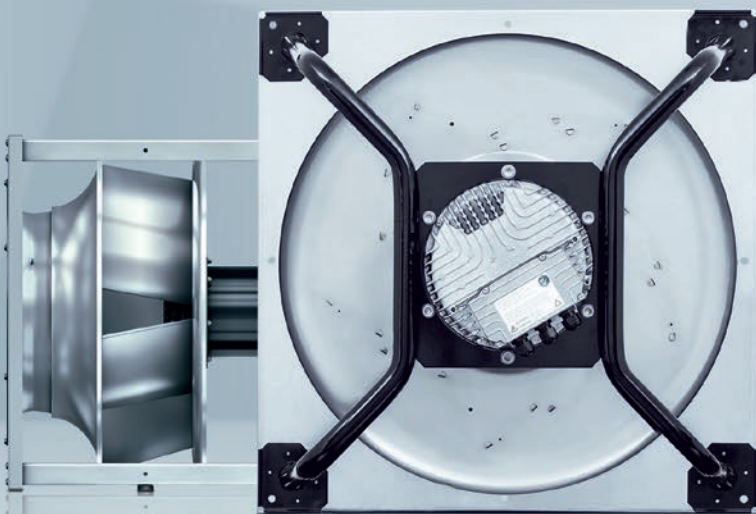

# A coherent concept.

## RadiPac stands for ...

**Realistic performance specifications**, as the performance data of the entire fan is continuously measured by means of the components: high-performance impeller, GreenTech EC motor and control electronics.

**Effective logistics**, as a single RadiPac part number includes all components required for your ventilation demands – in the fashion of one-stop shopping.

**Simple commissioning**, as all features necessary for operation are already installed and adapted to one another.

### Simple and safe.

Together, the electronics and motor form one unit – this doesn't just save space, but also ensures easy installation: in this respect, control electronics replace an external frequency converter. What's more, as the motor and electronics in the motor system are already perfectly matched to one another and include a motor protecting switch, making additional electronic filters and shielded cables unnecessary. To sum up: there is no need for time-consuming programming during commissioning or for earthing and screening work. Plug & Play really is that simple.

## GreenTech EC fans

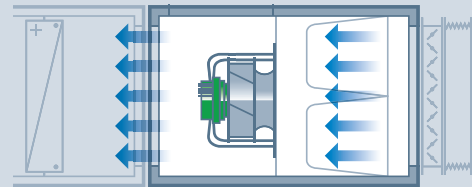

## Conventional fans

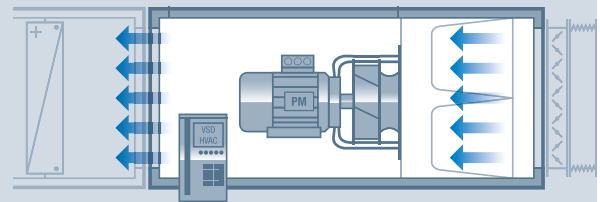

Permanent magnet motor (PM) with frequency converter

### Compact design.

The high-performance impeller is mounted directly on the rotor of the external rotor motor. This saves space and allows the entire rotating unit to be balanced at the same time.

## Conventional fans

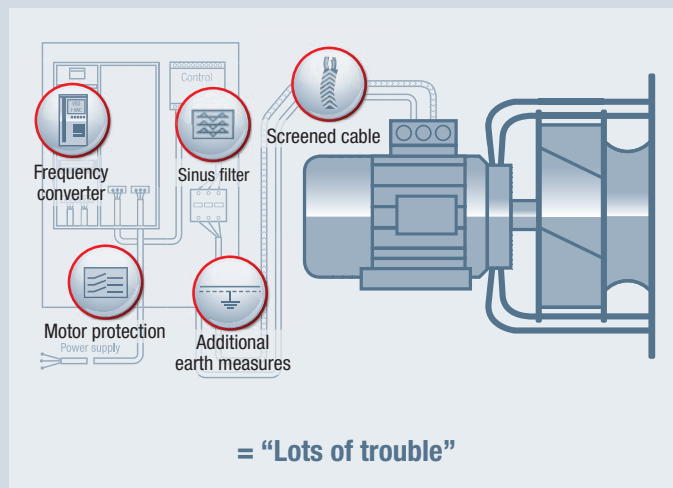

## GreenTech EC fans

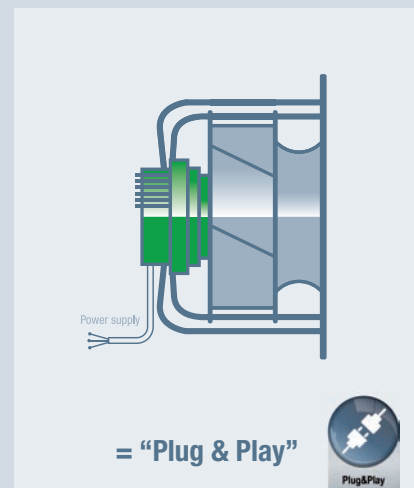

# It's all about efficiency.

Unfortunately, designers of air handling units often have bad experiences with the installed fans, as the fan data from the selection software fails to match the actual air flow and energy efficiency. This is not a problem when selecting a RadiPac fan. Only measured data are provided, and the available space for installation is taken into account.

## Design certainty for the system builder.

We took the real conditions of installation in air handling units into consideration while developing the RadiPac fans. In particular, we optimized the impeller's outflow characteristics and reduced the deflection losses in the air handling unit. In addition, a wide optimum efficiency range with static overall efficiency of 68% enables the fans to work in a wide operating range with low power consumption.

## A coherent concept.

The basis for the wide optimum efficiency range is the finely matched interaction of all fan components. For example, the Green-Tech EC motors with efficiencies of well over 90% more than meet the requirements of efficiency class IE4. Likewise, the design of the impeller contributes to increased efficiency and quiet operation. Improvements include, for example, the air intake into the impeller, the positioning of the external rotor motor in the impeller, and the blade profile. Overall, these measures have improved the efficiency of RadiPac fans by over 13% compared with the previous models.

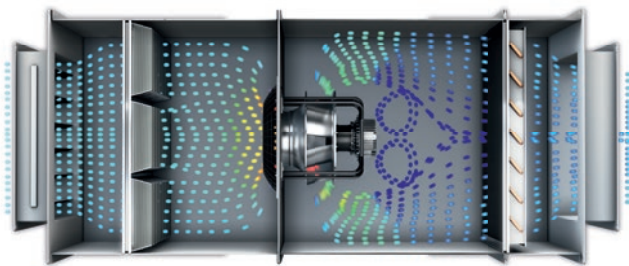

RadiPac with optimum flow behavior.

Wide optimum efficiency range: Isolines of the static overall efficiency in the characteristic diagram

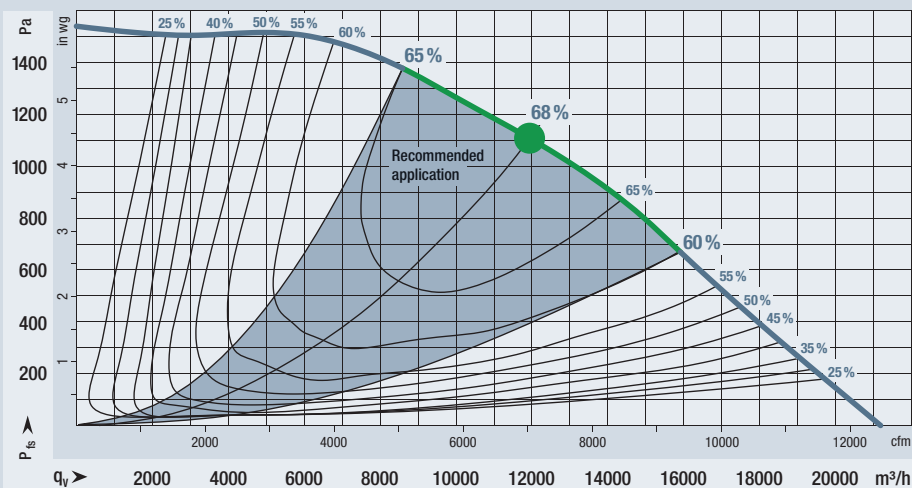

## Want to find out more?

We'll be happy to advise you.  
 Ralf Mühleck  
 Phone +49 7938 81-7035  
 Ralf.Muehleck@de.ebmpapst.com

or follow us at  
[www.ebmpapst.com/radipac](http://www.ebmpapst.com/radipac)

# Convincing performance.

The performance measurements for all fans are conducted on cutting-edge chamber test rigs. The entire fan unit, consisting of the motor, the control electronics and the impeller, is measured at different load levels. This provides us with reliable data, meaning that when you are choosing your fans, you can count on these values being met. This rules out any nasty surprises

when commissioning the fans. The measurement data form the basis for the selection program, FanScout, which is available on request.

This software enables you to calculate operational costs or to conduct a comprehensive cost analysis across the life-cycle.

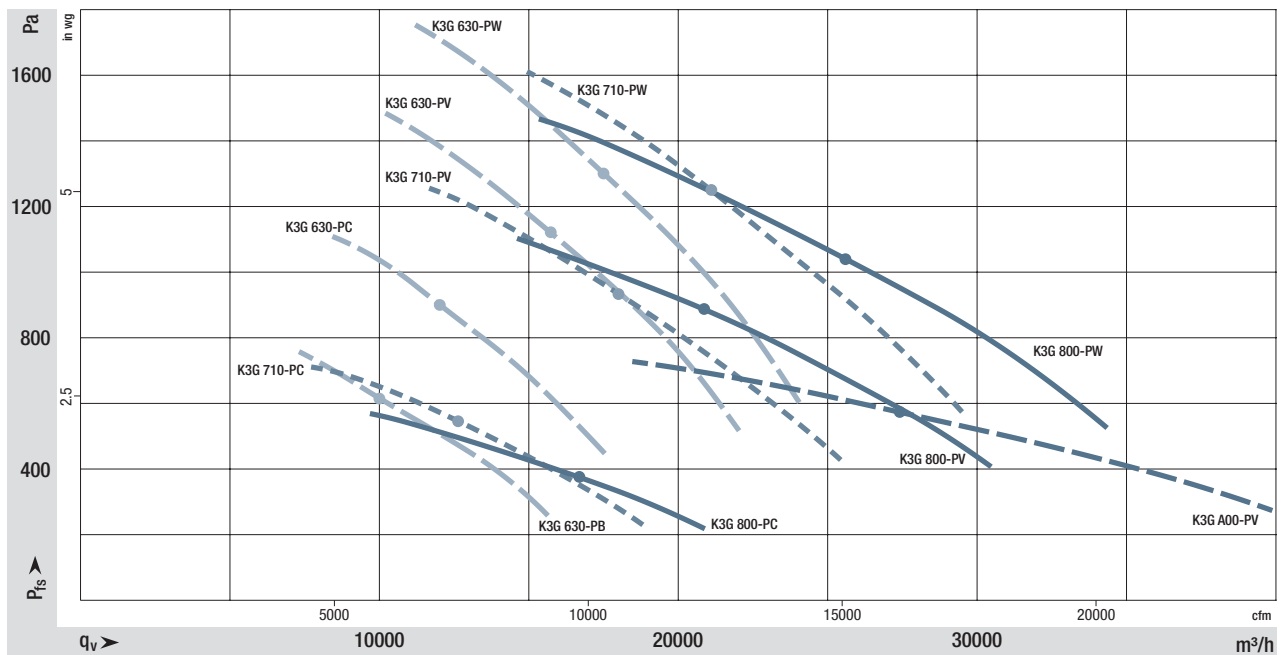

RadiPac nominal data			Nominal voltage range	Frequency	Speed	Max. input power	Max. input current	Perm. ambient temperature
Size	Article number	Design	VAC	Hz	rpm	W	A	°C
630	K3G 630-PB32-71	Support bracket	3~ 380-480	50/60	1,275	2,670	4.1	-25...+40
	K3G 630-PC08-01	Support bracket	3~ 380-480	50/60	1,530	4,600	7.1	-25...+40
	K3G 630-PV04-01	Cube	3~ 380-480	50/60	1,750	7,060	10.8	-25...+40
	K3G 630-PW04-01	Cube	3~ 380-480	50/60	1,950	9,670	15.1	-25...+40
710	K3G 710-PC05-71	Support bracket	3~ 380-480	50/60	1,060	2,900	4.5	-25...+40
	K3G 710-PV05-01	Cube	3~ 380-480	50/60	1,430	7,350	11.2	-25...+40
	K3G 710-PW06-01	Cube	3~ 380-480	50/60	1,680	11,900	18.3	-25...+40
800	K3G 800-PC12-71	Support bracket	3~ 380-480	50/60	835	2,600	4.0	-25...+40
	K3G 800-PV13-01	Cube	3~ 380-480	50/60	1,213	7,600	12.1	-25...+40
	K3G 800-PW07-01	Cube	3~ 380-480	50/60	1,370	11,300	17.5	-25...+40
1,000	K3G A00-PV03-01	Cube	3~ 380-480	50/60	750	6,340	9.8	-25...+40

Data is subject to change without notice at ebm-papst discretion.

Ideal interplay ensures that the whole is more than the sum of its parts.

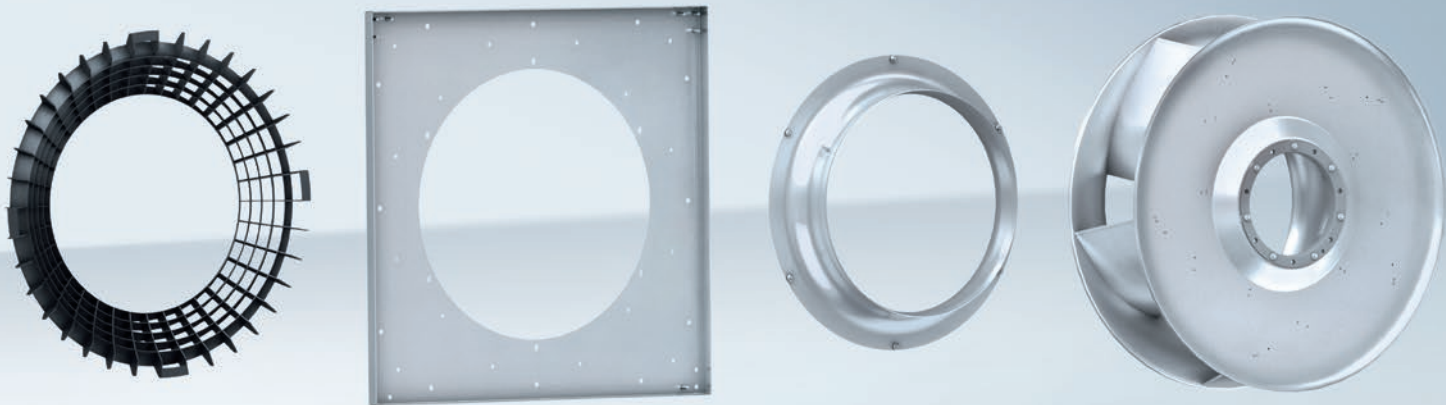

### FlowGrid

- + Reduced noise spectrum**
  - Low noise level
  - Dramatically dampened tonal noise
- + Retained efficiency**
  - Unchanged air performance
  - No effect on efficiency
- + Compact design**
  - Small footprint
  - Less insulation
- + Quick installation**
  - Through-holes for easy attachment
  - Customized attachments on request
- + Effective environmental protection**
  - Noise reduction as an essential component of environmentally friendly operation
- + Rugged design**
  - Made of durable composite material
  - Available up to flame-resistance standard UL94-5VA



### Inlet ring

- + Pre-installed**
  - Optimized factory positioning of nozzle
  - Pressure tap for air flow control standard
- + Low losses**
  - Optimized impeller inflow



### High-performance impeller

- + High static efficiency**
  - Aerodynamically optimized blade channel
  - Integrated radial diffuser
- + Low noise emission**
  - Diagonal trailing edge for optimized flow control
  - Integrated radial diffuser
- + Minimal vibration**
  - Dynamic balancing of impeller-rotor unit minimizes induced structure-borne noise and reduces bearing load
- + Rugged design**
  - Suitable for constantly high peripheral speed
  - Corrosion-resistant aluminum
  - Airfoil blade



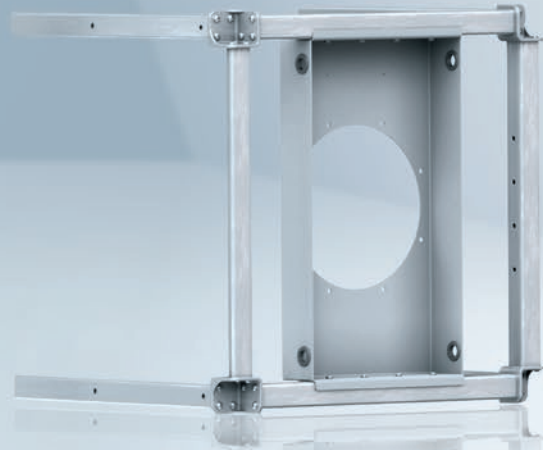

### GreenTech EC motor

### Electronics and connection area

### Support bracket/cube design

- + Unbeatably compact**
  - Impeller mounted directly on motor rotor
- + High efficiency**
  - Low copper and iron losses
  - Synchronous running prevents slip losses
  - Use of permanent magnets prevents magnetic hysteresis losses in rotor
- + Economical operation**
  - Optimized commutation for partial-load operation down to 1:10 while maintaining high efficiency
- + Low noise emission**
  - Commutation and stator design ensure low-noise magnetization of main field
  - High, acoustically imperceptible cycle frequency
- + Long service life**
  - Maintenance-free bearings
  - Brushless commutation
- + Safe operation**
  - Insulated bearing system to prevent bearing currents

- + Adaptable**
  - Continuously variable speed settings
  - Control signal of 0–10 VDC and MODBUS-RTU
- + Universally deployable**
  - Wide voltage range for use worldwide
  - Suitable for 50 and 60 Hz power lines
- + Safe operation**
  - Integrated locked-rotor and thermal overload protection
  - Environment-resistant cable glands
- + Simple commissioning**
  - Central terminal area for power connection, alarm relay, open-loop control and communication
  - Safe separation of terminal area and electronics
  - High-quality terminals
  - No programming effort

- + Easy installation in AHU**
  - Complete system for quick and easy installation
  - Nozzle plate for easy attachment of fan to equipment wall
  - Installation with horizontal OR vertical motor shaft
  - Compactness enables new design flexibility
- + Aerodynamically perfected**
  - Aerodynamically efficient
  - Optimized factory positioning of nozzle
- + Effective reduction of vibrations**
  - Cube design available with optional spring or rubber isolator elements



# The best solution in every case.

The large RadiPacs are available in a cube design or with support bracket in sizes from 630 to 1,000. The right version depends on the application. In any case, thanks to their perfectly integrated system and Plug & Play, installation is very simple.

## Rugged and sturdy: RadiPac cube design.

The RadiPac versions with cube design are made for floor mounting with horizontal shaft. In this scenario, the RadiPac can be installed with spring or rubber isolator elements for decoupling from vibrations. This design is also easy to handle and stackable for transport and storage. You also have a sustainability benefit as there is no packaging to begin with, so there is none to be disposed of.

Size	Article number	A	B	C	D
630	K3G 630-PV04-01	664	35	760	666
	K3G 630-PW04-01	711	35	760	666
710	K3G 710-PV05-01	749	40	960	786
	K3G 710-PW06-01	821	40	960	786
800	K3G 800-PV13-01	858	40	960	786
	K3G 800-PW07-01	880	40	960	786
1,000	K3G A00-PV03-01	873	45	1,180	1,036

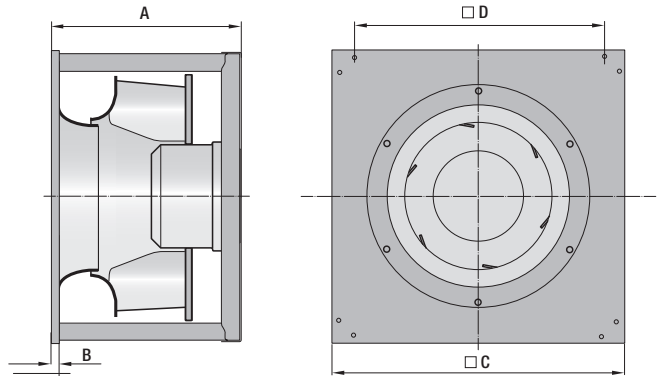

## Quickly installed: RadiPac with support bracket.

The unit can simply be mounted on the equipment wall using the pre-installed nozzle plate – safely and with little effort.

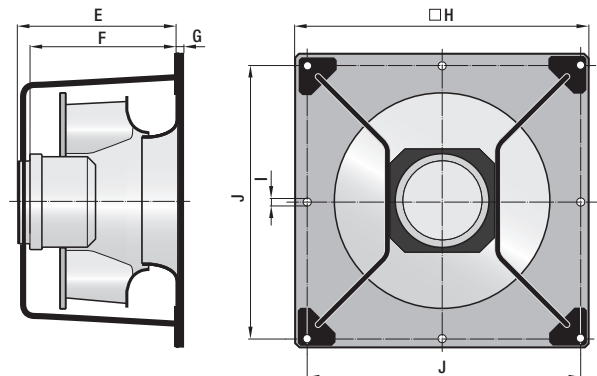

Size	Article number	E	F	G	H	I	J
630	K3G 630-PB32-71	537	468	15	800	Ø 11 (8x)	750
	K3G 630-PC08-01	586	473	15	800	Ø 11 (8x)	750
710	K3G 710-PC05-71	597	528	25	960	Ø 11 (12x)	820
800	K3G 800-PC12-71	657	588	25	960	Ø 11 (16x)	880

All specifications in mm, data sheet on request  
Data is subject to change without notice at ebm-papst discretion.

**ebm-papst**  
**Mulfingen GmbH & Co. KG**

Bachmühle 2  
74673 Mulfingen  
Germany  
Phone +49 7938 81-0  
Fax +49 7938 81-110  
[info1@de.ebmpapst.com](mailto:info1@de.ebmpapst.com)

**ebmpapst**

The engineer's choice