

Modbus Display & Control (MDC)

Document No: 210-OMI14229

Issue No: 10

Part No: CN1116 -Modbus Display & Control (MDC)

Manufacturer: ebm-papst UK Ltd

ebmpapst

engineering a better life



Table of Contents

.....	4
1.0 Safety Notice.....	5
2.0 Introduction.....	6
3.0 Overview.....	7
3.1 Specification.....	7
3.2 Installation.....	7
3.3 Hot plugging.....	7
3.4 RS485 wiring installation.....	7
4.0 Configuration and First Use.....	8
4.1 Electrical connections.....	8
4.2 General and initial power ON.....	8
4.3 First time controller configuration.....	9
4.3.1 Configuring the controller with fans that are in their factory default settings	9
4.3.2 Configuring the controller with fans that have been pre-configured by another MDC	10
4.4 Fan status screen.....	11
4.5 Power meter and summary screen.....	11
4.6 Swapping fan numbers and addresses.....	12
5.0 Operating Modes.....	12
5.1 General.....	12
5.2 Main menu access and operating mode configuration.....	13
5.3 Monitor mode (default operation).....	13
5.4 Monitor & control mode.....	14
5.4.1 Controlling the fan array speed using the controller's 0-10V input (0-10V Control Mode)	14
5.4.2 Controlling the fan array speed using the controller's RS485 Slave port (Modbus Control Mode)	15
5.4.3 Controlling the fan array speed using the controller's keypad (Keypad Control Mode)	16
5.4.4 Measuring fan performance using one or multiple pressure sensors	16
5.5 Constant volume or constant pressure operating mode.....	17
5.6 Modbus relay operating mode.....	18
6.0 Pressure Sensor Connections.....	18
7.0 Advanced Settings.....	19
8.0 Multi-Sensor Operation.....	22
8.1 Sensor wiring and airline connections.....	22
8.2 Controller configuration and automatic sensor mapping.....	23
8.3 Reading the volume from individual sensors (direct and shared sensors).....	25
9.0 Fault Indication.....	25
9.1 Loss of communication and fan alarms indications.....	25
9.2 Warning indications.....	26
9.3 Sensor Failures.....	26
10.0 Replacing the Controller.....	27
11.0 Replacing a Fan.....	27

12.0	WEEE (Waste Electrical and Electronic Equipment).....	28
13.0	End of life.....	28
14.0	Take Back Policy.....	28
15.0	Transport & Storage.....	28
16.0	Maintenance and servicing.....	28
17.0	UKCA / CE Certificates.....	28
Appendix A – Physical Details.....		29
Appendix B – Electrical Connections.....		30
Appendix C – Remote Monitoring & Control.....		31
C.1 Remote Monitoring.....		31
C.2 Remote Fan Array Control.....		31
C.3 Remote Speed Control – Individual Fans.....		32
Appendix D – Modbus Input Registers.....		32
Appendix E – Modbus Holding Registers for Configuration & Control.....		33
Appendix F – Modbus Holding Registers for Individual Fan Monitoring.....		37
Appendix G – Example of Modbus Relay Operation.....		39
Appendix H – Menu Structure Flow Chart.....		41
H1 – Fan Addressing - New Fan Array -Initial Setup.....		41
H2 – Fan Addressing - Existing Fan Array - Initial Setup.....		41
H3 – Initial Factory Reset.....		41
H4 – Fan Replacement.....		41
H5 – Main Menu.....		41
H6 – Fan Status.....		42
H7 – Operation Mode – Monitor.....		42
H8 – Operation Mode - Monitor & Control.....		42
H9 – Operation Mode - Monitor & Control – Keypad Control.....		43
H10 – Operation Mode - Constant Volume / Constant Pressure.....		43
H11 – Operation Mode - Modbus Relay.....		44
H12 – Advanced Settings Sub Menu.....		44
H13 – Adv. Settings - Sensor Reading H14 – Adv. Settings – Measurement Unit.....		45
H15 – Advanced Settings – PID Settings.....		45
H16 – Advanced Settings – RPM Limit.....		45
H17 – Adv. Settings – 0-10V Control Cap H18 – Adv. Settings – 0-10V Input Cap.....		45
.....		46
H19 – Advanced Settings – Alarm Output.....		46
H20 – Advanced Settings – BMS Settings.....		47
H21 – Advanced Settings – BMS Compatibility.....		47
H22 – Advanced Settings – Main Menu Lock.....		47
H23 – Diagnostics Menu.....		47
H24 – Fan Comms.....		48
H25 – Adv. Settings – LCD Brightness H26 – Adv. Settings – Erase Sensor Map.....		48
H27 – Advanced Settings – Factory Reset.....		48

Table of Figures

Figure 1 - Schematic of RS485 installation	7
Figure 2 – Typical wiring for Monitor Operating mode	8
Figure 3 - Fan status screen showing that the controller had a previously stored fan array	8
Figure 4 - Keypad buttons.....	9
Figure 5 - Main menu display screen on first application of power	9
Figure 6 - Fan status screen	11
Figure 7 – Power meter and Summary Screen.....	11
Figure 8 - Wiring diagram for Monitor operating mode – with optional pressure sensor	13
Figure 10 - Wiring diagram for Monitor & Control operating mode and 0-10V control mode – potentiometer control signal and external power supply	15
Figure 11 - Wiring diagram for Monitor & Control operating mode and 0-10V control mode – external control signal.....	15
Figure 12 - Wiring diagram for Monitor & Control operating mode - Modbus RS485 control signal.....	16
Figure 13 - Wiring diagram for Monitor & Control operating mode – keypad control	Error! Bookmark not defined.
Figure 14 - Wiring diagram for Monitor & Control operating mode – single sensor monitoring.....	16
Figure 15 - Typical wiring diagram for Constant volume / Constant pressure operating mode and controller sensor input	18
Figure 16 – Sensor airline connections for pressure and volume	19
Figure 17 – Airline length for a single sensor constant volume system or volume monitoring system	19
Figure 18 – Sensor-Fan wiring diagram with power supply	22
Figure 19 – Simplified sensor-fan wiring using ebm-papst differential pressure sensors.....	22
Figure 20 – Example of sensor airline connections in a 4-fan 2-sensors constant volume system.....	23
Figure 21 – Example of airline connections in a 4-fan 2-sensor constant pressure system.....	23
Figure 22 – Fan status screen showing individual sensor readings in m3/h	25
Figure 23 - Communication Lost Figure 24 - Fan Alarm	26
Figure 25 - Example of a first warning on a fan Figure 26 - Example of a second warning on a fan	26
Figure 27 – Sensor Fail Alarm Indication	27
Figure 28 – Exploded View of Product.....	28

Table of Tables

Table 1 - Information shown on the MDC	6
Table 2 - Specification.....	7
Table 3 – Supported Fan Modbus Port Configuration.....	10
Table 4 – PCB Bottom Side Connector Identities and Pin Functions.....	30
Table 5 – PCB Top Side Connector and Pin Function	Error! Bookmark not defined.
Table 6 - Modbus Input Registers	32
Table 7 – Controller’s Dedicated Modbus Holding Registers Part 1	33
Table 8 – Controller’s Dedicated Modbus Holding Registers Part 2	37
Table 9 – Fan Alarm and Fan Warning Register Breakdown.....	39
Table 10 – Full Modbus Relay Register Map (retrieved from fan registers)	40

Important

To assure proper usage, we ask you to read these operating instructions carefully before installation and commissioning of the control device

⚠ NOTE: The table below identifies the features compatible with your controller’s firmware issue number. This is shown on the LCD screen during power up and on the label at the back of the printed circuit board.

Firmware Issue	Notes
11	Updated handling of Gen 3 Fans in Monitor mode
10A and below	See previously released OMIs

⚠ NOTE:

If the controller’s RS485 Slave port is being used, and the system has been designed using a controller whose firmware issue is 6 or below, please activate the “BMS Compatibility” option according to the firmware issue of the previous controller. See **H21 – Advanced Settings – BMS Compatibility** for more details.

Please note that the “BMS Compatibility” option is only available after initial configuration.

1.0 Safety Notice

⚠ CAUTION – Safety

- The Modbus Display & Control is only suitable for a safety extra low voltage supply of 9VDC up to 57VDC

⚠ CAUTION – Electro-Static Discharge

- Many modern electronic components are susceptible to damage from Electro-Static Discharge (Static Electricity). During programming and commissioning, avoid unnecessary contact with electronic components on PCB’s. PCB’s are sensitive to static discharges so should be stored and transported in anti-static packaging until they are required to be used.

⚠ Warning – Do not operate in an explosive atmosphere

⚠ Warning – The fans may start during connection and programming. If there is a residual risk of contact with a fan, then contact shall be prevented by suitable control methods to prevent accidental contact

2.0 Introduction

The Modbus Display & Control (MDC) is a device with two RS485 ports, a keypad for setting parameters and a display to view the status of the connected equipment. The RS485 master port communicates with ebm-papst Modbus enabled, Electronically Commutated (EC) fans with software version 5.0 or later using a two-wire plus ground RS485 connection. The RS485 slave port communicates with an external Modbus Master device e.g. Building Management System (BMS) and provide real-time monitoring and control data.

The MDC features a Modbus auto-addressing program to ease installation and commissioning where it automatically searches and addresses up to 100 EC fans connected to its RS485 master port.

Four different operating modes are supported:

- Monitor:
 - Monitors pre-defined fan parameters and reports the information via the digital display and the RS485 slave port (see Tables 1 below).
 - A fault condition is raised by an on-board LED and a volt-free relay.
 - An optional 0-10V differential pressure sensor can provide a signal to the controller to display either differential pressure or used to calculate and display volume flow.
- Monitor & Control:
 - As per Monitor operating mode plus the fan speed is controlled by one, or a combination of:
 - An external 0-10V control signal connected to the controller's 0-10V input.
 - A third-party Modbus Master device connected to the controller's RS485 slave port.
 - Local control using the controller's keypad.
- Constant Volume / Constant Pressure:
 - As per Monitor operating mode but requires one or multiple 0-10V differential pressure sensors used by the controller to maintain a constant volume / constant pressure setpoint configured via the keypad and/or the RS485 slave port.
- Modbus Relay:
 - This operating mode converts the controller into a simple messenger where it relays all Modbus information received from the RS485 slave port to the master port, enabling individual fan control and access to all Modbus Registers of each fan.

The MDC will display the following parameters for each connected fan, and the following system parameters:

Fan Actual Speed (RPM)	Fan Set Point (%)	Fan Serial Number
Fan Motor Temperature (°C) *1	Fan Electronics Temperature (°C)	Fan Hours Run (h)
Fan Power Consumption (W)	Fan Warnings	Fan Alarms
Fan Air Volume (m ³ /h or CFM) or Fan Air Pressure (Pa or in.w.g) *2	System Power Consumption (kW)	Total System Volume (m ³ /h or CFM) or Total System Pressure (Pa or in.w.g) *2

Table 1 - Information shown on the MDC

⚠ Note *1 - The controller is compatible with all firmware versions of ebm-papst enabled Modbus EC fans version 5.0 and later, however, on 'Modbus LITE' reduced functionality fans, the parameter 'Motor Temperature' is not available.

⚠ Note *2 - Volume and pressure measurements require one or more external differential pressure sensors with a 0-10V output. The supported pressure ranges are 50Pa, 200Pa, 500Pa, 1000Pa, 2000Pa and 3500Pa.

3.0 Overview

3.1 Specification

Product	Modbus Display & Control - CN1116
Supply Voltage (Reverse Polarity Protected)	Two sets of connections are provided for either: <ul style="list-style-type: none"> • 9 VDC to 24VDC from an optional external PSU or • 10 VDC sourced from connection to at least two EC fans 10V reference outputs* in parallel. Note that fans' reference must be the ≥ 20 mA version.
Supply Current	20mA (low LDC backlight) – 40mA (full LCD backlight)
Enclosure	CN1116 – wall mount
Enclosure Dimensions	See Appendix A – Physical Details
Weight	204 g
Operating Environment	-20°C to +60°C, 90%RH at 40°C max.
LCD Backlight Lifespan	Typ. 50000 hours of continuous operation at full backlight
EMC Compliance	BS EN61000-6-3 (emissions) BS EN61000-6-2 (immunity)

* Patent GB 2 431 303

Table 2 - Specification

3.2 Installation

Avoid exposure to vibration, high temperatures. The unit shall be installed according to relevant safety guidelines and requirements. Attention should be paid to local regulations and guidance.

3.3 Hot plugging

Hot plugging the controller is permissible, however, if a new or replacement controller is not at factory default settings, it will need to be reset to such.

3.4 RS485 wiring installation

For reliable communication with the fans, it is recommended to use shielded twisted pair cable with 120Ω impedance (RS485 standard cable), in a “Daisy Chain” wiring layout, and run it separated from mains supply wiring. We recommend placing the controller at one end of the RS485 network and to add a 220Ω termination resistor at the other end of the network cable as shown below:

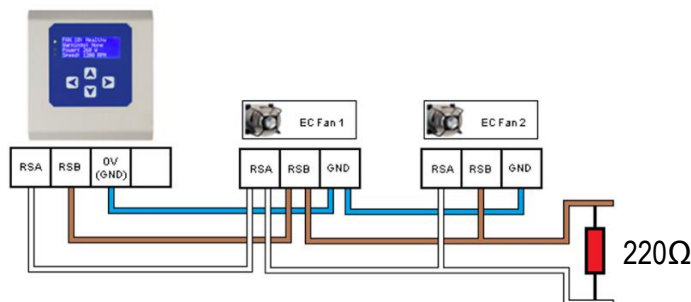

Figure 1 - Schematic of RS485 installation

In case the controller is in the middle of the network, the built-in termination resistor must be taken out of the circuit by removing the jumper bar located on back of the PCB. If that is the case, two resistors of the same value must be added at each end of the network.

210-OMI14229-Iss10	CN1116 Full OMI	Page 7 of 48
© ebm-papst UK Ltd 2025	Chelmsford Business Park Chelmsford Essex CM2 5EZ Telephone: +44(0)1245468555 Fax: +44(0)1245466336 e-mail sales@uk.ebmpapst.com	

4.0 Configuration and First Use

4.1 Electrical connections

The electrical connections are shown in **Appendix B – Electrical Connections**. The required connections to the controller depend on the intended use, i.e. the intended operating mode, and the desired configuration of fans, sensors, inputs and outputs.

A suggested connection diagram for each operating mode and their different configurations is shown in **Section 5.0 Operating Modes**. For the purpose of explaining the initial configuration and first use of the controller, the connection diagram for the controller’s factory default operating mode of “Monitor” is shown in Figure 2 below:

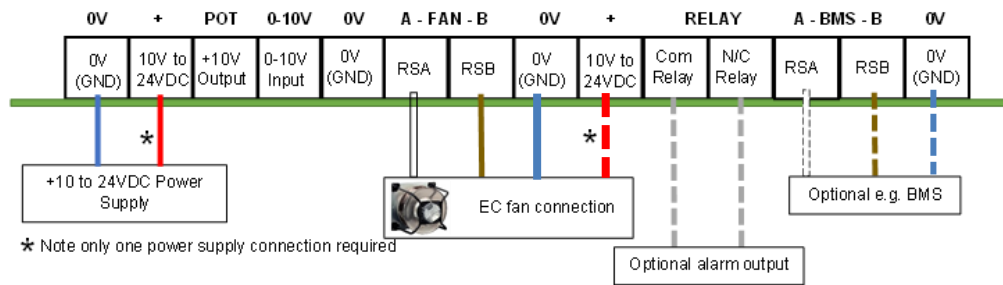

Figure 2 – Typical wiring for Monitor Operating mode

⚠ CAUTION: Risk of damaging the fans if two power supplies are connected at the same time:
Do not connect fans’ 10V output to the controller if the controller is powered from an external power supply.

4.2 General and initial power ON

When power is applied, the controller interrogates the on-board memory for a previously stored fan array and configuration parameters. If there is a previously stored fan array, the controller will display the status screen of the first fan in the array as shown in Figure 3 below. If there is no previously stored fan array the controller will display the Factory Default Main Menu screen where setup is required, see **4.3 First time controller configuration**.

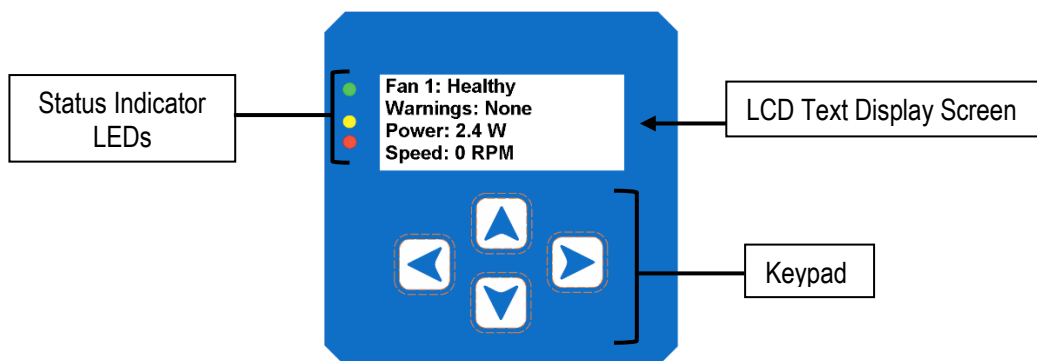

Figure 3 - Fan status screen showing that the controller had a previously stored fan array

The controller has three status indicator LEDs, an LCD text screen, and a keypad interface to navigate around the configuration menus and fan information.

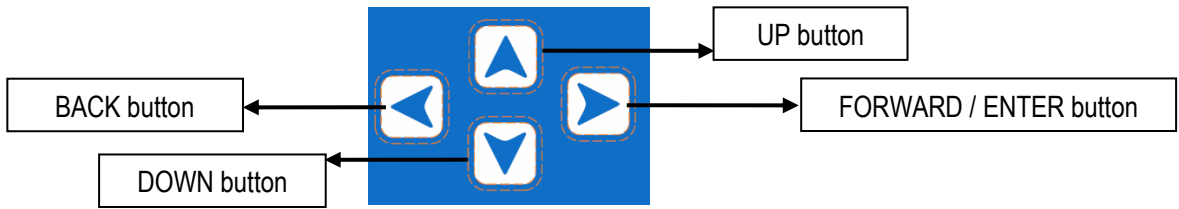

Figure 4 - Keypad buttons

- The FORWARD / ENTER button moves forward to the next fan if monitoring a fan’s status screen or confirms the request / change of a set value when configuring parameters inside the menus.
- The UP and DOWN buttons navigate through fan parameters when monitoring a fan’s status screen or changes the setpoints inside the menus.
- The BACK button moves back one step in the software structure without saving any changes made.

The menu structure flow chart is shown in **Appendix H – Menu Structure Flow Chart**.

Once the controller is configured and about to start normal operation, the green LED status indicator will be switched on and the controller will display the real time operating condition of the fans. It is possible to scroll through the network of connected fans to check set points, power consumption, alarm conditions and fan warnings from each fan by using the keypad interface.

When a fan enters an alarm state or has lost communication with the controller, the red LED status indicator will switch on and the display will show the fan that is experiencing the alarm as well as the details about that alarm.

If another fan in the array enters an alarm state, the controller will automatically display that fan’s alarm screen in order to always display the most recent fan experiencing a fault.

If a warning condition has been detected in any fan, the controller will illuminate the yellow fan status indicator LED but the display will not automatically show which fan has raised the warning. Fans that have entered a warning condition status can be found by navigating through the network of connected fans using the keypad buttons or by processing the controller’s Modbus registers using an external Modbus Master device connected to the controller’s RS485 Slave port.

4.3 First time controller configuration

The controller can be used on a new installation with fans delivered in their factory default condition or be used on an existing array of fans which have been networked and pre-addressed by another MDC. If the controller is used in a fan array previously configured by another device, in most cases it is only required to use the controller’s “Factory Reset” option before configuring the controller and fans.

4.3.1 Configuring the controller with fans that are in their factory default settings

New fans are typically supplied with factory default Modbus address 1 and factory default Modbus Port Configuration of 19200 baud rate, even parity and 1 stop bit. New controllers are supplied without any stored fan array configurations and on first application of power to the controller, the Main Menu will be displayed as shown in Figure 5 below:



Figure 5 - Main menu display screen on first application of power

For the controller to locate and address the fans in the network, all fans must be factory default Modbus Address 1 and with one of the supported Modbus Port Configuration shown in Table 3 below:

210-OMI14229-Iss10	CN1116 Full OMI	Page 9 of 48
© ebm-papst UK Ltd 2025	Chelmsford Business Park Chelmsford Essex CM2 5EZ Telephone: +44(0)1245468555 Fax: +44(0)1245466336 e-mail sales@uk.ebmpapst.com	

19200 Even 1 Stop Bit (default)	19200 Odd 1 Stop Bit	19200 None (1 or 2 Stop Bits)
9600 Even 1 Stop Bit	9600 Odd 1 Stop Bit	9600 None (1 or 2 Stop Bits)

Table 3 – Supported Fan Modbus Port Configuration

Please note that the Modbus Port Configuration must be the same across all fans in the network.

⚠ Important: Modbus Port Configurations that are not supported might still work because of the fan’s “Emergency Function” feature. However, this is not guaranteed, and it is not recommended to leave the system running with fans at their Emergency Function state. A manual change of each fan’s Modbus Port Configuration is strongly recommended using a combination of external devices such as a PC/laptop plus USB to RS485 converter and EC Control software

For fans that are not at their default Modbus Address 1, the controller is able to reset all connected fans to that address using the “Factory Reset” option. Once that has been completed, please follow the steps below to address the fans and start monitoring and/or controlling them:

- Select ‘Fan Addressing’ followed by ‘New Fan Array’ followed by the FORWARD button. See **H1 – Fan Addressing - New Fan Array -Initial Setup**.
- If three or more fans are connected to the controller, we recommend using the “Autodetect” configuration where the controller automatically detects the total number of fans in the network. It is possible to manually enter the total number of fans using the UP and DOWN buttons, and then press the ENTER button twice to confirm.
- If only two or one fan is connected to the controller please manually enter the number using the UP and DOWN buttons and then press the ENTER button twice to confirm.

The fan addressing is performed in ascending order, where fans with the lowest serial number have the lowest Modbus Address and Fan Number assigned by the controller. The first assigned Modbus Address to a fan is always 2. See an example below of a fan array consisting of 3 fans:

Fan Z has Serial Number 1327006PDZ – Controller Assigns Modbus Address 2 – this is FAN 1.

Fan X has Serial Number 1527006PDS – Controller Assigns Modbus Address 3 – this is FAN 2.

Fan Y has Serial Number 1527006PDZ – Controller Assigns Modbus Address 4 – this is FAN 3.

⚠ Important

After the fans have been automatically addressed it is possible to manually swap fan numbers between fans using the “Fan Re-Addressing” option inside “Main Menu”. See **4.6 Swapping fan numbers and addresses**

The auto addressing option will not be shown after all fans have been addressed. This can be reversed using the “Factory Reset” option inside “Main Menu -> Advanced Settings”

In case of an error during auto addressing, the fans must be physically inspected to ensure they are correctly wired and switched ON before retrying. It is also recommended, in all cases, to reset the controller and fans to factory settings before retrying.

4.3.2 Configuring the controller with fans that have been pre-configured by another MDC

Select “Fan Addressing” followed by “Existing Fan Array”. The controller will verify and display how many fans it has detected, and then ask for confirmation. If the number of fans detected is correct, press the ENTER button twice to confirm. If the number of fans detected is wrong, please manually inspect the fans and wiring and then retry.

4.4 Fan status screen

When the controller has finished addressing all fans in the array, the new fan array is saved in the controller's non-volatile memory. For a large group of fans this may take some time as the controller must interrogate each individual fan for their serial numbers. Once this process is completed, a "Change Fan Address" prompt screen will appear, and in case it is desirable to swap fan positions in the network please see **4.6 Swapping fan numbers and addresses**. These procedures only happen once per configuration, and the controller will then default to 'Monitor' operating mode and the status screen of Fan 1 will be displayed as shown in Figure 6 below:

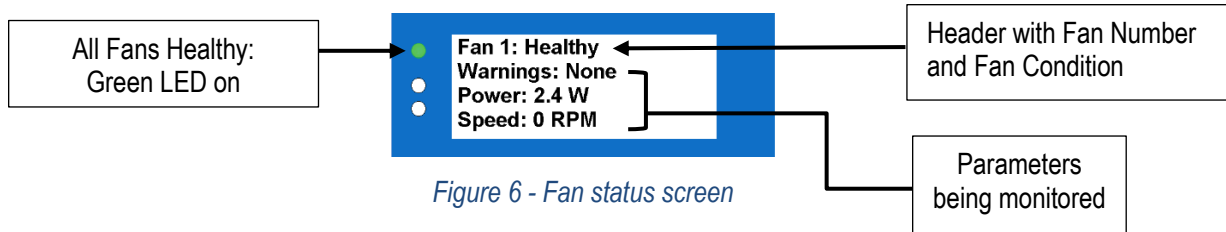

Figure 6 - Fan status screen

The following parameters are displayed for each fan in the network, three at a time:

- Fan Condition – Healthy / Alarm / Warning / No Comms
- Warnings – Description of warnings being experienced by the fan
- Power – Power consumption (W)
- Speed – Real-time fan speed (RPM)
- Motor temperature - °C (not available for Modbus Lite reduced electronics fans)
- Electronics Temperature - °C
- Hours Run – Number of fan operational hours
- Fan control - % of maximum input signal
- Serial Number – Manufacturing serial number
- Sensor Reading (available if the controller has been configured to work with multiple pressure sensors)

Use the 'UP' and 'DOWN' buttons to cycle between different parameters, and the BACK and ENTER buttons to cycle between different fans.

4.5 Power meter and summary screen

The power meter and summary screen is accessible by pressing the ENTER button when displaying the status screen of the last fan in the array. An example of a power meter and summary screen is shown in Figure 7 below:

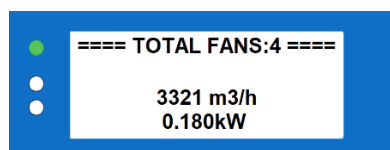

Figure 7 – Power meter and Summary Screen

The top row has a summary text containing the number of fans in the system and the number of fans experiencing alarms and/or warnings. The screen also shows the total volume/pressure of the system if one or more pressure sensors have been installed and configured. In the example above, the real-time volume flow of the system is shown in m3/h. If a volume/pressure alarm has been configured and triggered by the system, the second row will change from blank to a "Volume Alarm Active" or "Pressure Alarm Active" text, the red LED status indicator will switch on and (if configured) the alarm relay will open. The total power consumption of the system is shown in the bottom row and consists of the sum of the power consumption from each fan converted to kilowatts.

⚠ Note: If a fan experiences alarms, warnings or communication loss, the controller will remain in the "power meter and summary" screen but will switch on the red LED (communication loss and fan alarms) and/or the yellow LED (fan warnings).

4.6 Swapping fan numbers and addresses

The automatic assignment of Modbus addresses to fans can be inconvenient for the user as the preference for the fan addresses/numbers may be to follow a logical addressing based on the position of the fans in the array or building. For this reason, it is possible to swap fan numbers and addresses such as to match the equipment or building layout.

This option becomes available in the main menu under 'Fan Re-Addressing' option once the fans have initially been found and auto-addressed by the controller. Under this option, a list of fans is displayed where it is possible to see each fan's fan number, Modbus address and serial number.

In cases where it is desirable to match the fan numbers with the equipment or building layout, and if the installation has a circuit breaker for each fan installed in the desired equipment or building layout, we recommend switching one of the fans off using the fan's circuit breaker while on the Fan Readdressing menu and then checking which fan serial number changed to an "Alarm" (and eventually "No Comms") text.

Take note of that fan's number together with the circuit breaker number, switch the fan back on and move to the next fan. Once all fans have been processed, the notes will become a guide of how to proceed in swapping fan numbers to achieve a match between the fan numbers and the equipment or building layout.

By selecting a fan from the list and pressing the ENTER button, it is possible to assign a new fan number/Modbus address to that fan by using the UP and DOWN buttons. Press ENTER again and the controller will assign the selected fan number/Modbus address to the fan.

⚠ Note 1: As a fan changes its fan number and address, the fan currently at that target fan number and address will be changed to the selected fan's old fan number and address - effectively "swapping" them.

⚠ Note 2: This feature is not available when using the controller with only one fan.

⚠ Note 3: It is not possible to assign a fan number outside the total number of fans e.g. if using the controller with a 4-fan array, the fan numbers will be restricted to 1-4, with the corresponding Modbus addresses 2-5.

⚠ Note 4: It is not possible to change the fan number and address when using "Fan" as a "Sensor Input".

5.0 Operating Modes

5.1 General

The controller can be configured to operate in four different modes:

- Monitor (Default)
- Monitor & Control
- Constant Volume/ Constant Pressure
- Modbus Relay

In "Monitor" operating mode the fans remain in their factory default settings where they are speed controlled using their 0-10V inputs. In "Monitor & Control" and "Constant Volume / Constant Pressure" modes the controller automatically changes the settings of each fan to allow speed control via Modbus and the analogue inputs of the fans can no longer be used for speed control. The controller automatically changes the speed control method of each fan when changing between different operating modes so there is no need to manually connect to each fan and configure its speed control method.

210-OMI14229-Iss10	CN1116 Full OMI	Page 12 of 48
© ebm-papst UK Ltd 2025	Chelmsford Business Park Chelmsford Essex CM2 5EZ Telephone: +44(0)1245468555 Fax: +44(0)1245466336 e-mail sales@uk.ebmpapst.com	

5.2 Main menu access and operating mode configuration

Changing the operating mode (and other configurable parameters) is possible via the Main Menu, which can be accessed using the controller's keypad. To access the Main Menu, scroll through the fan status pages using the BACK button until the status of the first fan is shown. The Main Menu can then be accessed from there by pressing the BACK button twice. See **H6 – Fan Status** for more details.

In cases where it is desirable to prevent unauthorised access to the main menu, please see **H22 – Advanced Settings – Main Menu Lock** for details on how to activate the main menu lock and the key sequence to allow authorised access.

⚠ IMPORTANT

The “Operating Mode” submenu will only become available inside the main menu once all fans have been addressed. The main menu is intended for configuration purposes only - the entire controller's monitor and/or control operations will be halted whilst in any of its submenus except 'Set Speed' submenu.

After 5 minutes of inactivity inside the main menu or any of its submenus (except the “Diagnostics Menu”) the controller will power cycle and resume its normal monitor and/or control operations.

Most changes made in the main menu and its submenus (either locally or remotely via the Modbus Slave Port) will trigger a power reset to both fans and controller, required to activate the new parameters.

5.3 Monitor mode (default operation)

In “Monitor” operating mode, the fans are following a speed control command from a separate source connected to each fan's 0-10V input. The controller acts as a monitoring device where it extracts information from each fan via Modbus and displays on the LCD screen. This information is also available to an external Modbus Master device connected to the controller's Modbus Slave Port, typically a BMS.

It is possible to monitor either a pressure differential or calculate the real-time volume flow by using an external differential pressure sensor connected to the controller's 0-10V input. This information is displayed in the Power Meter and Summary Screen, see **4.5 Power meter and summary screen**.

A typical wiring diagram for Monitor operating mode is shown below. The pressure sensor connection is optional.

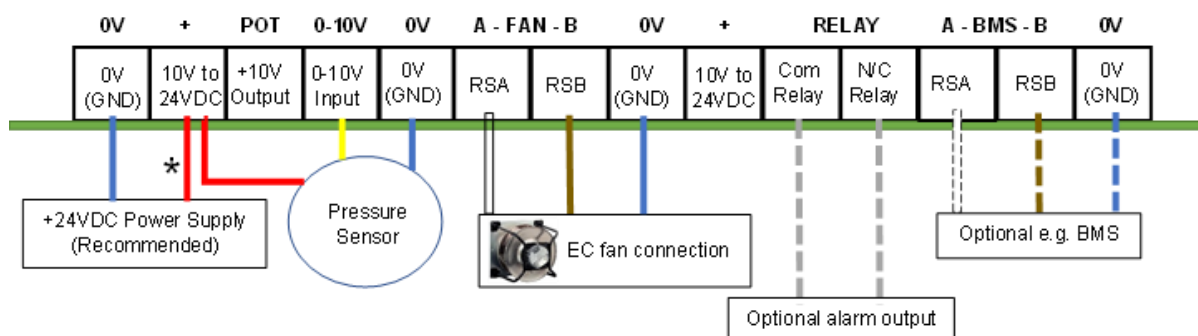

Figure 8 - Wiring diagram for Monitor operating mode – with optional pressure sensor

If connecting a pressure sensor, please see **Section 6.0 Pressure Sensor Connections** where it shows how to correctly install the pressure sensor to the fan and/or the equipment.

⚠ CAUTION: Risk of damaging the fans if two power supplies are connected at the same time
Do not connect fans' 10VDC output to the controller if the controller is powered from an external power supply.

⚠ CAUTION: Risk of damaging the sensor if the controller’s power supply voltage exceeds the maximum voltage input of the sensor. All “+” controller terminals are common.
Check the sensor voltage input rating before connecting it to the controller.

⚠ CAUTION: Risk of damaging the controller’s 0-10V input. Any signals higher than 10V may damage the 0-10V input of the controller.
Check the sensor voltage output range before connecting it to the controller.

5.4 Monitor & control mode

In “Monitor & Control” operating mode the fans no longer respond to a separate speed signal i.e. a 0-10V analogue signal connected to the analogue input terminal of each fan. Instead, all fans are automatically configured to Modbus speed control and receive the same speed setpoint from the controller via Modbus. The speed setpoint is based on inputs at the controller which are called “control modes”.

The controller supports three control modes: 0-10V, Modbus and Keypad and it is possible to set the controller to respond to each control mode individually or in a combination:

Single Control Option

If only one control mode is selected the controller will only respond to the output from the source specified i.e. if keypad control mode is specified, the controller will respond only to a speed setpoint change made at the keypad.

Multiple Control Options

There may be a requirement for more than one control mode option, such as in the case of manual override. Using multiple control modes prioritises the last instruction received.

Below an example of a sequence of events taking place to control the speed setpoint when all three control modes have been selected:

- 1) A 3.5V signal is connected to the 0-10V input of the controller - fans run at 35% speed.
- 2) An external Modbus Master device connected to the controller’s Modbus Slave Port writes a value of 50 to the controller’s Holding Register 4 - fans increase speed to 50%
- 3) The controller’s keypad is then used to slow the fans to 20% speed - the fans decrease their speed to 20%.
- 4) The external Modbus Master device writes 70 to the controller’s Holding Register 4 - the fans accelerate to 70% speed, etc.

⚠ IMPORTANT

If the speed setpoint is changed using the controller’s keypad or the 0-10V input control mode, the latest setpoint is recalled by the controller in the event of a power cycle. However, this does not apply in case the speed setpoint is changed using the Modbus control mode unless the “Save Modbus Control Speed Setpoint” register has been set.

5.4.1 Controlling the fan array speed using the controller’s 0-10V input (0-10V Control Mode)

The controller responds to a 0-10V signal connected to its 0-10V input terminal. This can be from either an external system or from a 10kΩ potentiometer connected to a +10VDC supply. The controller has a dedicated 10V output if required hence there are a few possible wiring diagrams for the 0-10V control mode:

210-OMI14229-Iss10	CN1116 Full OMI	Page 14 of 48
© ebm-papst UK Ltd 2025	Chelmsford Business Park Chelmsford Essex CM2 5EZ Telephone: +44(0)1245468555 Fax: +44(0)1245466336 e-mail sales@uk.ebmpapst.com	

⚠ IMPORTANT: When powering the controller using the 10V 10mA output from the fans it is required to use at least two fans' power supplies connected in parallel to provide enough current to the controller

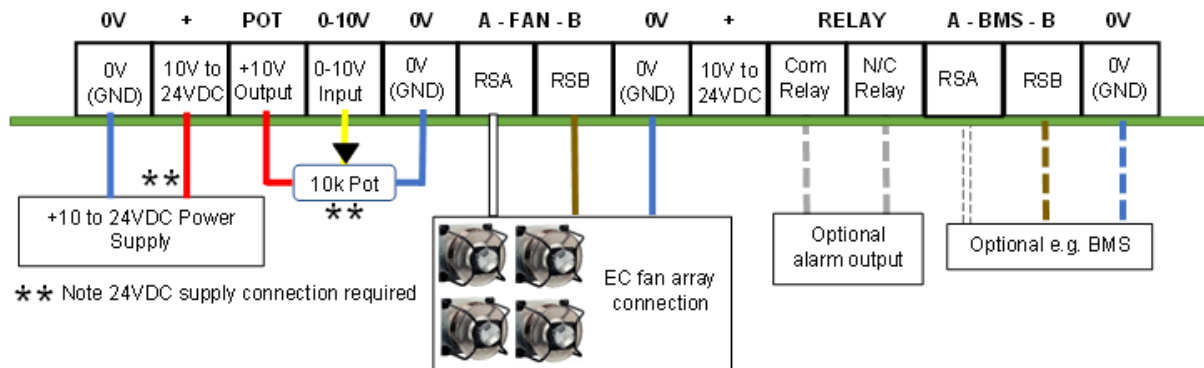

Figure 99 - Wiring diagram for Monitor & Control operating mode and 0-10V control mode – potentiometer control signal and external power supply

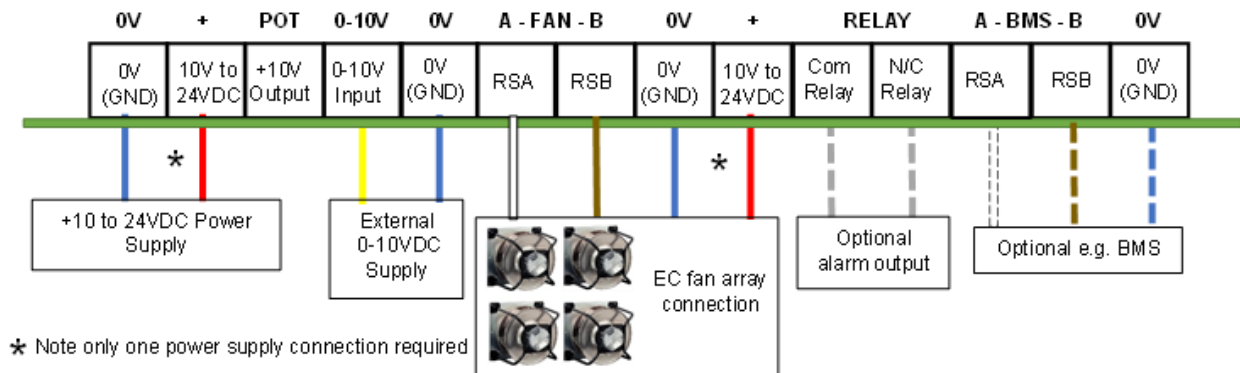

Figure 100 - Wiring diagram for Monitor & Control operating mode and 0-10V control mode – external control signal

⚠ CAUTION: Risk of damaging the fans if two power supplies are connected at the same time:
Do not connect fans' 10VDC output to the controller if the controller is powered from an external power supply.

5.4.2 Controlling the fan array speed using the controller's RS485 Slave port (Modbus Control Mode)

The controller is configured to receive Modbus commands from an external device connected to its RS485 slave port e.g. a BMS. The speed setpoint can be changed by writing a new value to the controller's Modbus holding register address 4. The value must be between 0 and 100 which the controller will then broadcast the new speed setpoint to all connected fans whilst retaining monitoring and alarm functionality.

The wiring diagram for this control mode is shown below:

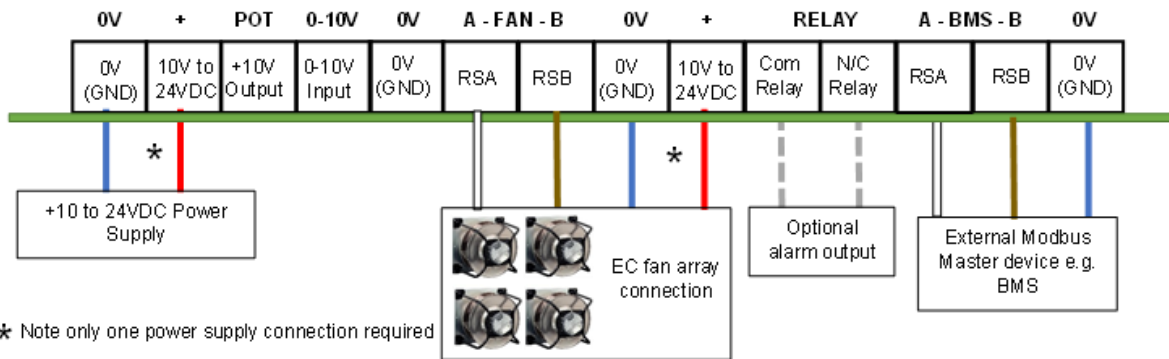

Figure 111 - Wiring diagram for Monitor & Control operating mode - Modbus RS485 control signal

⚠ CAUTION: Risk of damaging the fans if two power supplies are connected at the same time:
Do not connect fans' 10VDC output to the controller if the controller is powered from an external power supply.

5.4.3 Controlling the fan array speed using the controller's keypad (Keypad Control Mode)

A new submenu called "Set Speed" will become available inside the Main Menu where it is possible to set the speed setpoint using the keypad. See **H9 – Operation Mode - Monitor & Control – Keypad Control**. Use the UP and DOWN buttons to change the speed setpoint in steps of 1%, or hold the ENTER button and then use the UP and DOWN buttons to change the speed setpoint in steps of 25%.

5.4.4 Measuring fan performance using one or multiple pressure sensors

When "Monitor & Control" operating mode is selected, it is possible to monitor a 0-10V differential pressure sensor connected to the 0-10V input of the controller or to the 0-10V input of the fan. Select "Enabled" when the "Sensor Monitor" screen appears during the configuration of the operating mode. Then select the "Sensor Input" to either "Controller" or "Fan". Please note that if the selected "Sensor Input" is set to "Controller", the 0-10V control mode will become unavailable.

The wiring diagram when using a differential pressure sensor connected to the controller:

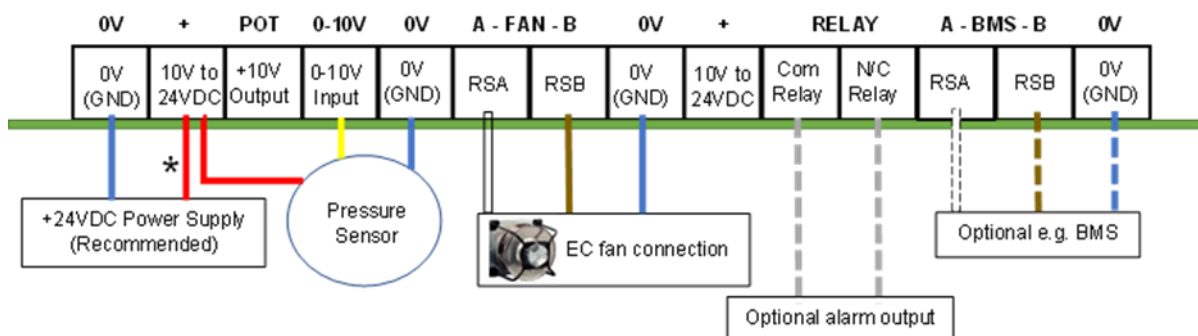

Figure 12 - Wiring diagram for Monitor & Control operating mode – single sensor monitoring

See **Section 6.0 Pressure Sensor Connections** where it shows how to correctly install the pressure sensor to the fan and/or the equipment.

⚠ CAUTION: Risk of damaging the fans if two power supplies are connected at the same time:
Do not connect fans' 10VDC output to the controller if the controller is powered from an external power supply.

⚠ CAUTION: Risk of damaging the sensor if the controller's power supply voltage exceeds the maximum voltage input of the sensor. All "+" controller terminals are common:
Check the sensor voltage input rating before connecting it to the controller.

⚠ CAUTION: Risk of damaging the controller's 0-10V input. Any signals higher than 12V may damage the 0-10V input of the controller:
Check the sensor voltage output range before connecting it to the controller.

To monitor one or more pressure sensors using the 0-10V input of the fans, select "Fan" as the "Sensor Input". Please see **Section 8.0 Multi-Sensor Operation** for more details.

5.5 Constant volume or constant pressure operating mode

The controller can be used with one or multiple 0-10V differential pressure sensors to maintain a volume or pressure set point in the system in which the fans are installed. The controller automatically controls the speed of the fans based on the input from the sensors and the configured constant volume or constant pressure setpoint.

If the controller is set to Constant Volume / Constant Pressure operating mode, the Power Meter and Summary Screen will include a real-time display of the volume / pressure being maintained by the fan array as reported by one or multiple differential pressure sensors.

From the Power Meter and Summary Screen, it is possible to adjust the constant volume/pressure setpoint using the keypad by pressing the ENTER button twice whilst holding UP and DOWN buttons, see **H6 – Fan Status**. It is also possible to adjust the constant volume/pressure setpoint via Modbus, please see **Appendix E – Modbus Holding Registers for Configuration & Control**.

A volume or pressure alarm can be configured (see **H19 – Advanced Settings – Alarm Output**) which will trip when the fans reach 100% speed and the reported volume / pressure is below the constant volume / pressure setpoint. There is a time delay between when the alarm condition is sensed and when the controller opens the alarm relay and turns on the red LED status indicator.

The response of the system when in Constant Volume / Constant Pressure mode is adjusted by changing the Proportional, Integral and Derivative (PID) parameters using either the 'Main Menu>Advanced Settings>PID Settings' submenu or remotely via Modbus. Please see **Appendix E – Modbus Holding Registers for Configuration & Control** for more details.

The wiring diagram when using a single pressure sensor is shown below:

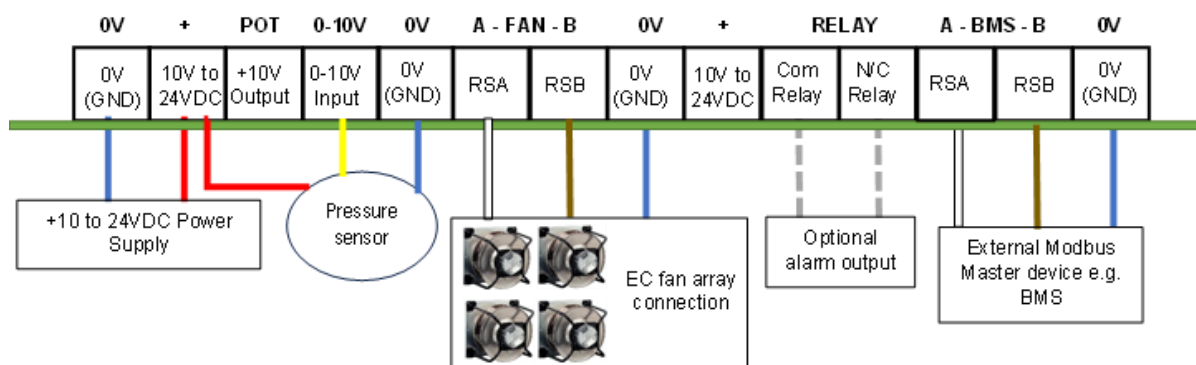

Figure 123 - Typical wiring diagram for Constant volume / Constant pressure operating mode and controller sensor input

⚠ CAUTION: Risk of damaging the fans if two power supplies are connected at the same time:
Do not connect fans' 10VDC output to the controller if the controller is powered from an external power supply.

⚠ CAUTION: Risk of damaging the sensor if the controller power supply voltage exceeds the maximum voltage input of the sensor. All "+" controller terminals are common:
Check the sensor voltage input rating before connecting it to the controller.

⚠ CAUTION: Risk of damaging the controller's 0-10V input. Any signals higher than 10V may damage the 0-10V input of the controller:
Check the sensor voltage output range before connecting it to the controller.

To use the controller with multiple sensors please see **Section 8.0 Multi-Sensor Operation** for more information. See **Section 6.0 Pressure Sensor Connections** where it shows how to correctly install the pressure sensor to the fan and/or the equipment.

5.6 Modbus relay operating mode

The controller can be installed on an RS485 Modbus network and configured to act as a relay between the fans and Modbus Master device e.g. BMS. In Modbus Relay operating mode the controller ceases all control and monitor operations and becomes a relay for messages and commands between the Modbus Master device.

This operating mode allows exclusive access to all Modbus registers on each fan according to the latest ebmpapst parameter specification for Modbus enabled motors. A copy of this parameter specification is available on request by e-mail at info@uk.ebmpapst.com.

See **Appendix G – Example of Modbus Relay Operation** for a working example of the Modbus Relay operation.

6.0 Pressure Sensor Connections

For a constant volume, or a volume monitoring system the differential pressure sensor must measure the pressure difference between the fan inlet ring tapings and the fan air supply side. This is different for a constant pressure, or a pressure monitoring system where the inlet ring is not required, and the sensor must measure the pressure difference between the fan air supply and the fan exhaust. The figure below shows exactly where to connect the differential pressure sensor positive and negative tapings:

210-OMI14229-Iss10	CN1116 Full OMI	Page 18 of 48
© ebm-papst UK Ltd 2025	Chelmsford Business Park Chelmsford Essex CM2 5EZ Telephone: +44(0)1245468555 Fax: +44(0)1245466336 e-mail sales@uk.ebmpapst.com	

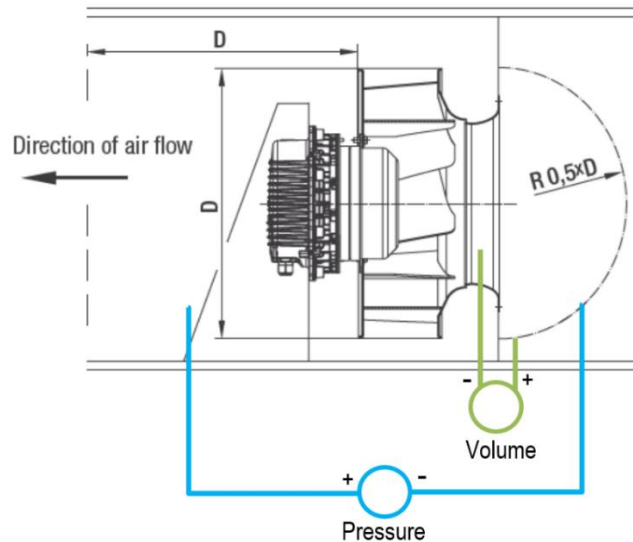

Figure 13 – Sensor airline connections for pressure and volume

When using inlet rings, due to potential disturbances it is recommended to use a multi-tapped inlet ring which provides an averaged pressure value over all taps to improve the precision of the air volume measurement. If this system operates with a single sensor, the precision of the air volume measurement can be improved further by ensuring that all inlet ring tappings are equidistant from the sensor as shown below:

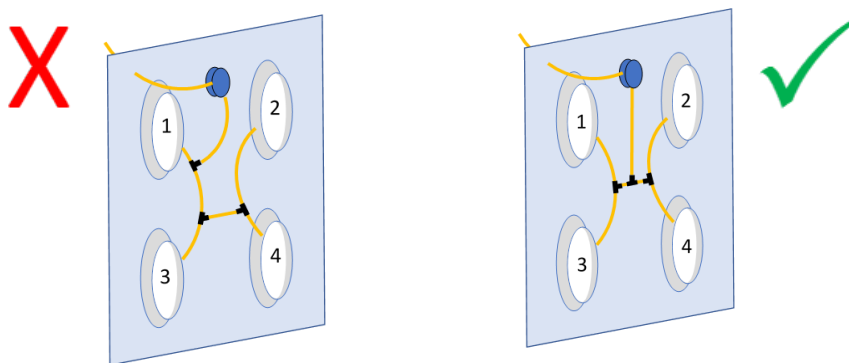

Figure 14 – Airline length for a single sensor constant volume system or volume monitoring system

Instead of using a single differential pressure sensor, it is possible to connect multiple differential pressure sensors to the system by using the 0-10V inputs of the fans. The operation with multiple differential pressure sensors can improve reading accuracy and introduce another fail-safe layer to the system operation as the controller automatically adjusts the settings in the event of a sensor failure. For more details, please see **Section 8.0 Multi-Sensor Operation**.

7.0 Advanced Settings

The advanced settings submenu allows the configuration of different controller and fan parameters. We recommend reading and understanding this whole section before making any changes.

A list of all available submenus inside the Advanced Settings submenu is shown below. Please note that not all submenus are available at once and their availability depends on the selected operating mode and if the controller has been configured to operate with or without differential pressure sensors:

210-OMI14229-Iss10	CN1116 Full OMI	Page 19 of 48
© ebm-papst UK Ltd 2025	Chelmsford Business Park Chelmsford Essex CM2 5EZ Telephone: +44(0)1245468555 Fax: +44(0)1245466336 e-mail sales@uk.ebmpapst.com	

Measurement Unit (See H13 – Adv. Settings - Sensor Reading H14 – Adv. Settings – Measurement Unit): this submenu is only available when the controller has been configured to read one or more differential pressure sensors and it allows the selection between metric and imperial:

- m³/h (cubic metre per hour) or CFM (cubic feet per minute) for volume.
- Pa (Pascal) or in.w.g. (inch water gauge) for pressure.

PID Settings (See H15 – Advanced Settings – PID Settings): this submenu is only available when the controller's operating mode has been configured to constant volume/constant pressure and it allows the configuration of the P, I and D elements of the controller's PID control.

 **Caution:** Incorrect PID settings may cause unstable operation of the control loop

Sensor Reading (See H13 – Adv. Settings - Sensor Reading H14 – Adv. Settings – Measurement Unit): this submenu is only available when using two or more differential pressure sensors and it allows the configuration of how the total volume/pressure is calculated after all sensors have been read by the controller:

- Sum (default value for volume): the sum of all sensor readings
- Average (default value for pressure): the average across all sensors
- Minimum: the lowest value across all sensors
- Maximum: the highest value across all sensors

RPM Limit (See H16 – Advanced Settings – RPM Limit) : configures the maximum RPM limit of the fans. The new settings will be stored in non-volatile memory in the fans, after which the fans and controller will perform a power reset to activate the new operating parameters.

- **RPM Limit All Fans**
 - **Custom RPM:** Broadcasts a custom RPM to all fans.
 - **Set to Max RPM:** Read the maximum RPM limit of each fan and use this data to set each fan to its maximum RPM limit.
- **RPM Limit Single Fan:** Provides a list of all fans and their individual RPM limits to allow setting the RPM limit individually.

0-10V Control Cap (See H17 – Adv. Settings – 0-10V Control Cap): this submenu is only available when the controller has been configured to “Monitor” mode and it allows the configuration of the minimum and maximum 0-10V control input the fans will respond to. The values configured here are broadcast to all fans and stored in their non-volatile memory followed by a power reset to activate the new parameters.

0-10V Input Cap (See H17 – Adv. Settings – 0-10V Control Cap H18 – Adv. Settings – 0-10V Input Cap): this submenu is only available when the controller has been configured to “Monitor & Control” operating mode and it allows the configuration of the minimum and maximum 0-10V control input the controller will respond to. Values configured here are saved in the controller's non-volatile memory and used to cap the speed setpoint sent to fans.

Alarm Output (See H19 – Advanced Settings – Alarm Output): configures the alarm output settings such as enabled/disabling the onboard relay and selecting the type of faults that will cause the alarm to trip:

- **Relay Operation:** on this submenu it is possible to enable the onboard relay operation and select if fan alarms, fan warnings or both would cause the relay to open.
- **Volume/Pressure Alarm:** available when monitoring a sensor or when in constant volume / pressure operating mode.

- If monitoring a sensor, a threshold must be set for the relay to open and the red LED to switch on when the sensor reading is below that threshold. This threshold is set to 50% by default.

Example: Using a 500Pa differential pressure sensor in a pressure monitoring system and setting the pressure alarm threshold to 50%, the alarm relay will open whenever the pressure is below 250Pa.

- If in constant volume or constant pressure operation, it is not possible to set the threshold as it is fixed to 100%. The alarm relay will open when the fan array reaches 100% speed and the total volume/pressure reading is below the target volume/pressure setpoint.

In case of a volume / pressure alarm trip, a “Volume Alarm” or “Pressure Alarm” text will appear on the second line of the LCD screen when inside the “Power Meter and Summary Screen” and the red LED status indicator will switch on. Only the latter applies in case the controller is displaying a fan status screen.

BMS Settings (See H20 – Advanced Settings – BMS Settings): configures the parameters of the controller’s Modbus Slave port. If used, the baud rate, parity and stop bits configured here must be the same as those configured in the Modbus Master system e.g. BMS. The Modbus Slave default settings are:

- Modbus Address: 1
- Baud Rate: 9600
- Parity: None
- Stop Bits: 1

BMS Compatibility (See H21 – Advanced Settings – BMS Compatibility): this submenu is intended to provide backwards compatibility between the BMS and previous versions of the controller.

Menu Lock (See H22 – Advanced Settings – Main Menu Lock): enables/disables normal access to the Main Menu screen. If enabled, the Main Menu is only accessible when using a sequence of key presses available at the end of this document. The default value is “disabled”.

LDC Brightness (See H25 – Adv. Settings – LCD Brightness): allows the selection of different LCD backlight brightness levels, or to disable the backlight entirely. Care must be taken when changing this in case the controller is powered by a two fan 10V 10mA supply as highest brightness settings may take more current and display flickering may occur hence we recommend leaving on the “Autodetect” default option to avoid this.

Erase Sensor Map (See H25 – Adv. Settings – LCD Brightness H26 – Adv. Settings – Erase Sensor Map): this submenu is only available when using one or more differential pressure sensors connected to the fans and it allows the sensor mapper to run again by erasing the current sensor map stored in the controller’s non-volatile memory.

Diagnostics Menu (See H23 – Diagnostics Menu): this submenu is intended for diagnostics of the RS485 wiring between the fans and the controller. It provides an overview of the installation by showing a list of fans numbers, Modbus addresses and fan serial numbers. The list is constantly monitored by the controller and in case one or more fans lose their communication to the controller the list will display a “No Comms” in place of that fan’s serial number. Use the UP and DOWN buttons to scroll up/down the list and to select a different fan. Use the ENTER button to enter “Ping Mode” where the controller will send constant Modbus messages to the selected fan and display how many messages have been received or lost.

Fan Comms (See H24 – Fan Comms): this submenu menu displays the Modbus Port configuration (baud rate, parity and stop bits) of the fans and the controller (MDC). In case of a mismatch, it is possible to change the controller to the same Modbus Port Configuration as the fans providing it is within the supported configuration table see **Table 3 – Supported Fan Modbus Port Configuration**. In case the fan Modbus Port configuration is not

210-OMI14229-Iss10	CN1116 Full OMI	Page 21 of 48
© ebm-papst UK Ltd 2025	Chelmsford Business Park Chelmsford Essex CM2 5EZ Telephone: +44(0)1245468555 Fax: +44(0)1245466336 e-mail sales@uk.ebmpapst.com	

supported by the controller we recommend manually changing each fan to the factory default settings of 19200 Even 1.

Factory Reset (See H27 – Advanced Settings – Factory Reset): Resets the controller to factory default settings and all connected fans to Modbus address 1 and 0-10V control.

8.0 Multi-Sensor Operation

The controller can operate with multiple 0-10V differential pressure sensors to increase air flow measurement accuracy, display air volume/pressure of individual fans and add system redundancy in case of sensor failures. This section contains information about sensor wiring, airline connections and how to setup the controller for multi-sensor operation.

8.1 Sensor wiring and airline connections

Wiring: Connect the 0-10V output from the sensor to the fan’s 0-10V input. The wiring diagram below applies to differential pressure sensors that require an external power supply:

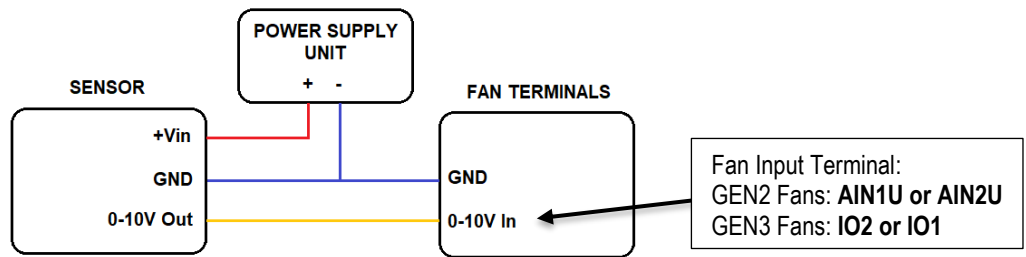

Figure 15 – Sensor-Fan wiring diagram with power supply

We recommend using ebm-papst SN1120 or SN1121 series differential pressure sensors as they have been specifically designed for fan arrays and can be powered from a fan’s 10V 10mA, or 24V supply. It simplifies the installation as shown in the new wiring diagram below:

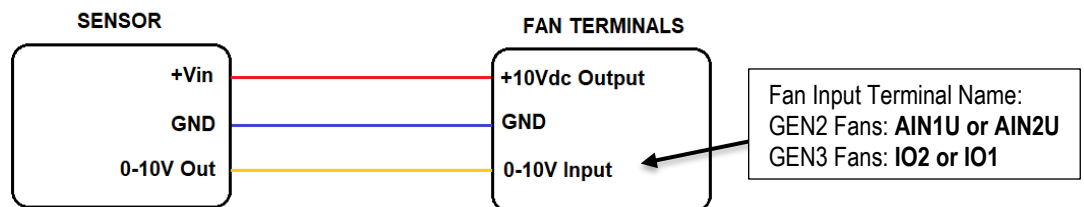

Figure 16 – Simplified sensor-fan wiring using ebm-papst differential pressure sensors

ebm-papst SN1120 and SN1121 differential pressure sensors can greatly reduce commissioning time, cost and complexity of the installation by eliminating the external power supply, sensor zero adjustment and specific mounting positions as they can be mounted at any given orientation without compromising their accuracy.

⚠ Note 1: Do not connect more than one sensor per fan.

⚠ Note 2: Please ensure that the selected fan 0-10V input terminal where the sensor output is connected to is the same as the 0-10V input terminal configured at the controller in the “Fan Sensor Input” menu. See **8.2 Controller configuration and automatic sensor mapping.**

Airline connections (constant volume / volume monitoring): Care must be taken to keep the connections equidistant from the sensor. An example of “4 fans 2 sensors” system is shown below:

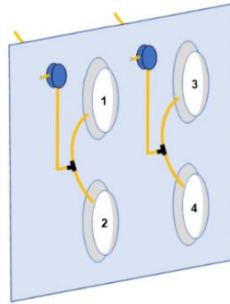

Figure 17 – Example of sensor airline connections in a 4-fan 2-sensors constant volume system

⚠ Note: All sensors must have the same pressure range

Airline connections (constant pressure / pressure monitoring): Inlet rings are not required for constant pressure or pressure monitoring systems, and therefore one of the airlines can be placed anywhere in front of the fans and the other is placed anywhere behind the fans. An example of a “4 fan 2-sensor” constant pressure system or pressure monitoring system is shown below.

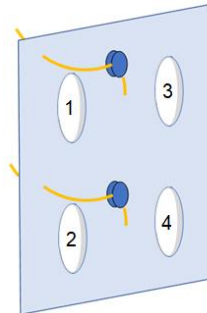

Figure 18 – Example of airline connections in a 4-fan 2-sensor constant pressure system

⚠ Note: All sensors must have the same pressure range

8.2 Controller configuration and automatic sensor mapping

How to set the parameters: after selecting either “Constant Volume / Pressure” as the operating mode, or “Monitor & Control” with “Sensor Monitor Enabled”, select “Fan” as the “Sensor Input” and then select the input terminal of the fan where the sensor is connected to. Proceed with the configuration of the other parameters e.g. target unit, sensor type, etc, and once finished, the controller will reset and start the “Sensor Mapper” where tests will be performed by the controller to identify all pressure sensors in the system.

⚠ Important: Ensure the area around the fans is clear and personal access is prevented before acknowledging the “Sensor Mapper” warning screen as the controller will immediately run all fans at a potentially high speed.

⚠ Note 1: Multi-sensor operation is not permissible during “Monitor” operating mode. In that case, the “Sensor Input” will be defaulted to “Controller” and the controller will look for a 0-10V differential pressure signal at its own 0-10V input terminal instead.

⚠ Note 2: It is possible to abort the sensor mapping process by selecting the “Abort” option. The controller will then be automatically set to Monitor and Control operating mode, with the control mode as per last configuration and sensor monitoring disabled.

Automatic sensor mapping

After the acknowledgment of the warning screen, the controller will run all fans at a fixed set speed, search for sensors at the selected analogue input of each fan and then present the results on the screen. If the controller cannot find any sensors, or the number of sensors found is incorrect, it is possible to retry the process by selecting the applicable option. For each retry, the test speed setpoint will increase by 10%.

⚠ Important

In case the test speed has reached 100% and the number of sensors is zero or different than the number of sensors installed please ensure that all pressure sensor connections have been made according to **Section 6.0 Pressure Sensor Connections** and the sensor wiring, airline connections and controller configuration have been made according to **Section 8.0 Multi-Sensor Operation**.

⚠ Note

It is possible to swap the configured fan analogue input during sensor mapping in which case the test speed will be reinitialised to 50%.

Once the correct number of sensors has been shown and acknowledged, the sensor mapper will display different screens based on the operating mode and unit type configuration of the controller:

If the controller has been configured for constant pressure or pressure monitoring: see “Finalising sensor mapping process” below.

If the controller has been configured for constant volume: if the number of sensors detected is lower than the total number of fans, the sensor mapper will automatically move to a sequence of tests called “Airline Dependency Check” where it will run a single fan at a time (only fans that do not have sensors) and then read all previously detected sensors to identify to which sensor that fan’s airline is connected to. After all tests have been completed, please see “Finalising the sensor mapping process” below.

If the controller has been configured for volume monitoring: like the constant volume configuration but it is possible to skip the entire “Airline Dependency Check” process by selecting the “Skip” option. However, in cases where a dependency check is required for one or more (but not all) sensor-less fans, it is possible to skip the check in a fan-by-fan basis by letting it run once and then selecting the “Skip” option when the error screen appears. This will cause the sensor mapper to skip the dependency check for that fan and move to the next fan.

Finalising the sensor mapping process

Before finalising the sensor mapping process, a fan-sensor list is presented on the screen where it shows one fan and one sensor per row. Sensors are numbered in ascending order of detection and categorised in two columns: direct and shared. A fan with a “direct” sensor is a fan that has a pressure sensor connected to its 0-10V input terminal. In case of constant volume or volume monitoring configurations, this fan also has its inlet ring connected to that sensor. A fan with a “shared” sensor is a fan that has its inlet ring connected to a sensor but does not have a sensor connected to its 0-10V input terminal.

Use the UP and DOWN buttons for scrolling up/down, and the ENTER button to accept the sensor map. Once the sensor map has been accepted, the controller will save the sensor map in its non-volatile memory, apply a power reset and resume normal operation.

⚠ Important: Please ensure that the final screen correctly matches the installation before accepting the sensor map. If that is not the case please check the physical connections between the fans and sensors, the sensors and inlet rings (or the equipment) and then restart the mapping process by selecting the “Retry” option using the BACK button.

210-OMI14229-Iss10	CN1116 Full OMI	Page 24 of 48
© ebm-papst UK Ltd 2025	Chelmsford Business Park Chelmsford Essex CM2 5EZ Telephone: +44(0)1245468555 Fax: +44(0)1245466336 e-mail sales@uk.ebmpapst.com	

Upgrading/downgrading the installation after mapping all sensors

When upgrading/downgrading the installation with the purpose of adding or removing sensors, it is necessary to run the Sensor Mapper again. The currently stored sensor map must be erased by going to “Main Menu -> Advanced Settings -> Erase Sensor Map”. The controller will then power cycle and automatically enter “Sensor Mapping” mode.

8.3 Reading the volume from individual sensors (direct and shared sensors)

A simple “2 fan 1 sensor” system is used as an example. Only the airline connections and the sensor’s 0-10V wire are shown below for explanation purposes:

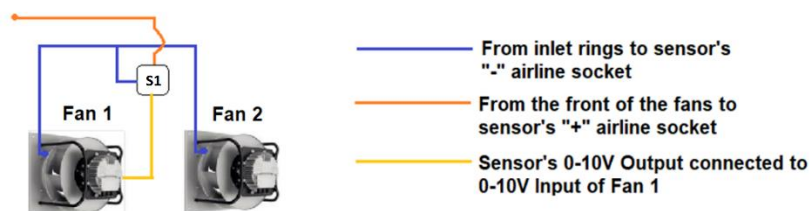

The individual volume readings are displayed in the fan status screen as shown below:

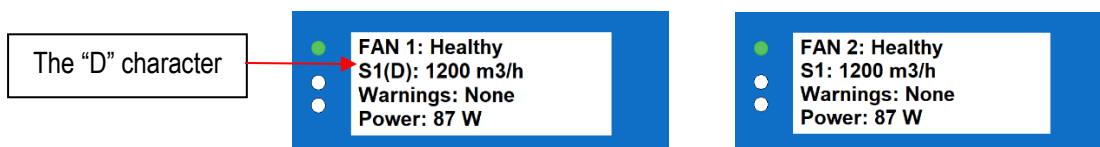

Figure 19 – Fan status screen showing individual sensor readings in m3/h

When looking at the status screen of fan 1, the volume reading line contains a “D” character prefix which indicates that the sensor’s 0-10V output is connected directly to the 0-10V input of fan 1.

However, when looking at the status screen of fan 2, the volume reading line does not contain the “D” prefix which indicates that the volume reading of fan 2 depends on sensor 1 (S1).

9.0 Fault Indication

The controller displays faults respecting the priority level of each fault type as shown below:

- Loss of Modbus communication between the controller and the fans – High Priority
- Fan Alarms – Medium Priority
- Fan Warnings – Low Priority

9.1 Loss of communication and fan alarms indications

When the controller loses communication with a fan, or identifies a fan alarm, it will switch on the red LED and skip to that fan’s status screen. If another loss of communication (or fan alarm) is identified in a different fan, the controller will skip to that fan’s status screen to always display the most recent fault.

Please note that screen skipping will not occur when the controller is at the “Power Meter and Summary Screen”. In that case, the controller will switch on the red LED and update the summary text to include the total number of fans experiencing an alarm and/or a communication loss.

The fan status screen of a fan experiencing an alarm or loss of communication will change as per examples below:

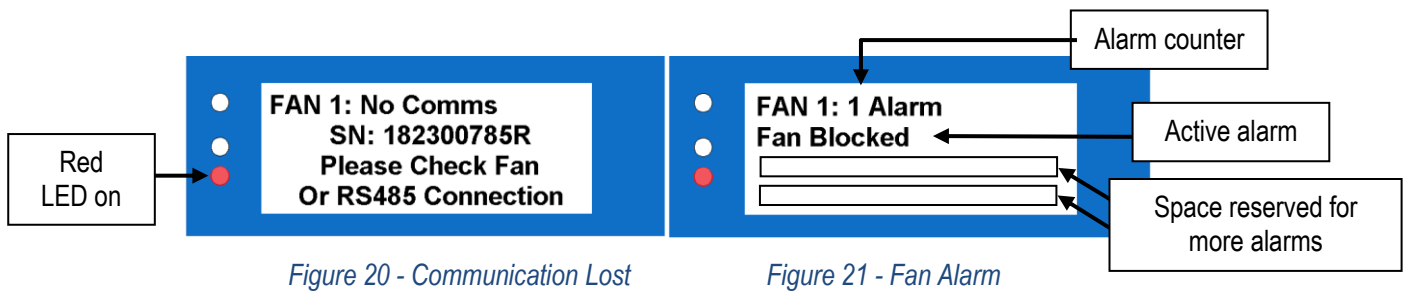

Figure 20 - Communication Lost

Figure 21 - Fan Alarm

If a fan has more than one alarm, they will be displayed in a list as they occur, and the alarm counter will increment. The controller's screen can display up to 3 fan alarms per fan.

9.2 Warning indications

In contrast to a communication loss or a fan alarm, the controller will not skip to a fan's status screen in case of one or more fan warnings. Instead, the controller will switch on the yellow LED, and once that fan's status screen has been manually located, the controller will indicate the active warnings of that fan as shown in the example below:



Figure 22 - Example of a first warning on a fan

Figure 23 - Example of a second warning on a fan

When a fan has more than one warning, they will be displayed in sequence on the same line, approximately 3 seconds apart from each other e.g. figures 26 and 27 above are separated by approximately 3 seconds.

⚠ Note: If the fan is switched off after experiencing alarms or warnings, the controller will, in most cases, temporarily save the alarms and/or warnings of that fan to a Modbus holding register value. See **Appendix F – Modbus Holding Registers** for more details. Please note that those holding registers will be defaulted to '0' if the controller is power cycled.

9.3 Sensor Failures

When using the fans as sensor inputs, it is possible to detect failed sensors based on the RPM reading of the fan and the sensor's differential pressure signal (in Pa).

The default threshold values are "300 RPM" and "2 Pa" and a "sensor fail alarm" will be triggered when both following statements are true:

1. Fan RPM > RPM threshold
2. Sensor Differential Pressure Signal (Pa) < Pa threshold

The accuracy in detecting failed sensors greatly depends on the values of those thresholds which can be configured inside Main Menu -> Advanced Settings -> Alarm Output -> Sensor Fail Alarm.

⚠ Note: This is an experimental feature and should not be used as a fundamental part of a healthy running system as it has the potential of false positive / negative alarms. It is therefore disabled by default.

When a “sensor fail” alarm occurs, the controller will switch its red LED on and display one of the following screens:

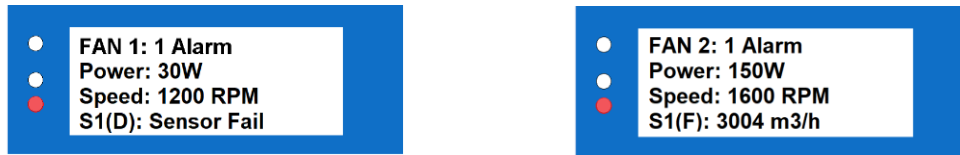

Figure 24 – Sensor Fail Alarm Indication

If a fan is directly connected to a sensor, the volume/pressure reading will be replaced with a “Sensor Fail” text. On the other hand, if the fan is not directly connected to a sensor but shares an inlet ring connection with a failed sensor, the character “F” will appear next to the sensor number indicating that that sensor has failed. When the system has two or more sensors and one fails, the fans that are connected to the failed sensor will be given individual volume/pressure readings based on the average individual volume/pressure readings of the other fans that are connected to healthy sensors. That is the case of fans 1 and 2 above: while fan 1 must display the “sensor fail” alarm text, fan 2 displays the “assumed” volume reading which is the same value given to fan 1.

10.0 Replacing the Controller

If the controller unit becomes faulty and needs to be replaced, ensure that the new controller is at its factory default settings before connecting it to the fan network. Select “Fan Addressing” and “Existing Fan Array”. Wait for the verification to finish and then either proceed with the suggested number of fans, or manually select the number of fans in the array using the UP and DOWN buttons. Finally, confirm by pressing the ENTER button - the controller will then power cycle and display the status screen of Fan 1.

⚠ Note 1: The new controller will not identify any set points or configuration parameters from its predecessor other than the fan speed control method e.g. Analogue 0-10V or RS485 because that is stored in the fans.

⚠ Note 2: The new controller must be manually re-configured to fully match its predecessor settings such as Operating Mode, Alarm Mode, BMS Settings, etc.

11.0 Replacing a Fan

The controller allows a single fan in the array to be replaced at a time. When replacing a fan, go to any fan’s status screen and then, if the fan to be replaced is still operating:

- Disconnect the fan to be replaced from the RS485 network and wait for the controller to display this fan’s status screen showing a “No Comms” alarm.
- Replace the fan and connect the new fan to the RS485 network.
- Switch the new fan ON.
- Wait for the controller to identify the new fan – a new screen should appear, see **H4 – Fan Replacement**.
- Press the ENTER button to add the new fan to the array: this will cause the controller to assign the same Modbus Address as its predecessor as well as the correct Speed Control method depending on the controller’s operating mode.

⚠ Important: The replacement fan must be at Modbus Slave Address 1 and have the same Modbus Port Configuration as the controller. To check the controller’s Modbus Port Configuration, go to “Advanced Settings -> Fan Comms -> MDC Comms”. In case of differences, the fan must be manually set to the required configuration using an external system such as a combination of computer/laptop + USB to RS485 converter + EC Control software.

12.0 WEEE (Waste Electrical and Electronic Equipment)

ebm-papst UK Ltd complies with the Waste Electrical and Electronic Equipment (WEEE) Regulations through membership of a producer compliance scheme (PCS) as a B2B producer. EEE Producer registration number: WEE/CA0209WR

13.0 End of life

This product has been designed to consider end-of-life disposal. If the product has come to the end of its life, the unit can be easily disassembled for the components to be recycled. The product has been designed to meet the requirements of the RoHS directive. Refer to the figure below when dismantling:

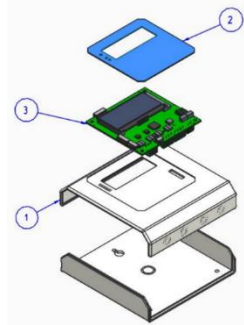

Figure 25 – Exploded View of Product

1. Enclosure – HIPS UL94-V0
2. Keypad membrane – polycoated Kraft, acrylic, polyester film and copper
3. Printed circuit board with electrical components – epoxy resin boded woven glass

14.0 Take Back Policy

As part of our commitment to minimise the disposal of Waste Electrical and Electronic Equipment (WEEE) customers can return the controller at the end of its life. Please contact us on 01245 468555 for details and issue of an end of life RMA number.

15.0 Transport & Storage

- PCBs not housed in enclosure should be transported in anti-static build-up bag or static dissipative bags.
- Store in a dry environment
- Storage temperature: -20°C to +60°C.

16.0 Maintenance and servicing

There are no user serviceable parts

17.0 UKCA / CE Certificates

The product has been UKCA and CE marked. The certificates are available upon request info@uk.ebmpapst.com

210-OMI14229-Iss10	CN1116 Full OMI	Page 28 of 48
© ebm-papst UK Ltd 2025	Chelmsford Business Park Chelmsford Essex CM2 5EZ Telephone: +44(0)1245468555 Fax: +44(0)1245466336 e-mail sales@uk.ebmpapst.com	

Appendix A – Physical Details

All dimensions in (mm)

BACK PLATE

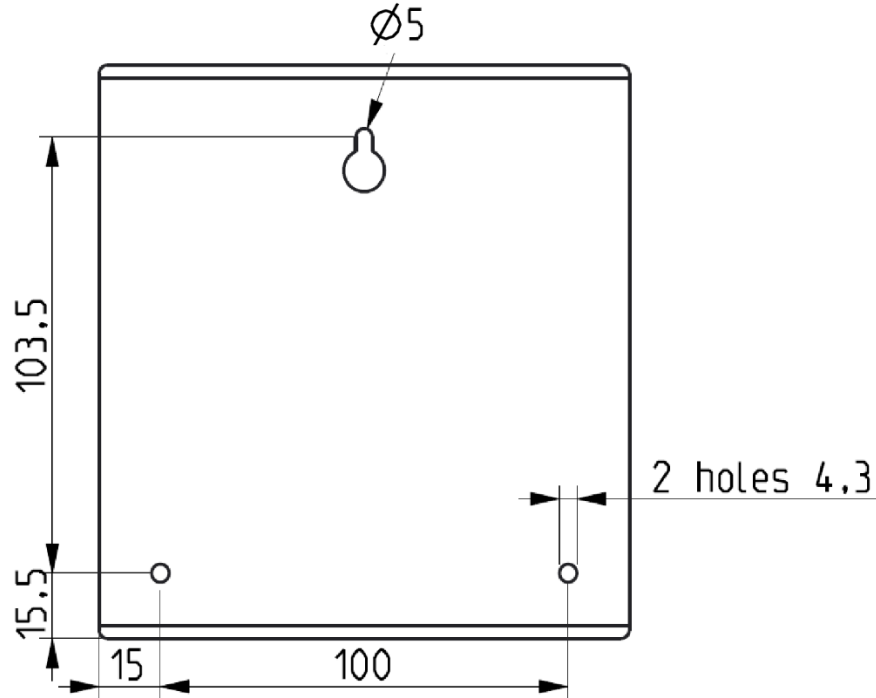

BOTTOM

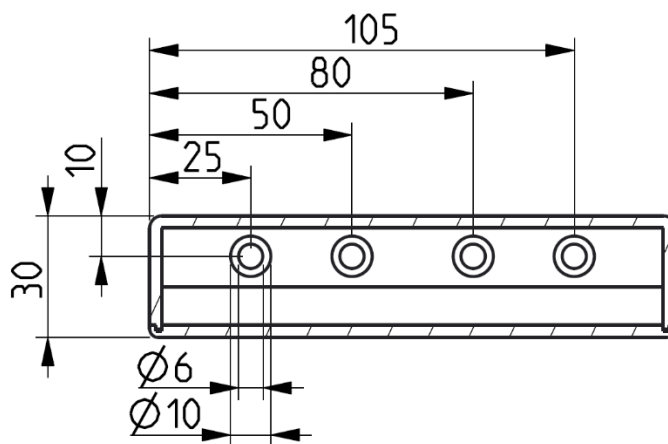

Appendix B – Electrical Connections

The following is an image of the PCB showing location and identity of the connectors and pin functions.

0V	+	POT	0-10V	0V	A - FAN - B		0V	+	RELAY		A - BMS - B		0V
0V (GND)	10V to 24VDC	+10V Output	0-10V Input	0V (GND)	RSA	RSB	0V (GND)	10V to 24VDC	Com Relay	N/C Relay	RSA	RSB	0V (GND)



Sealing Plug: **DO NOT CONNECT the 10VDC output from fans here if the controller is powered from an external power supply.**

PCB Label	Connection
0V	Common 0V (GND)
+	Power Supply +
POT	+10VDC Output (only when Supply is 24VDC)
0-10V	Speed Control Input / Pressure Sensor Input
0V	Common 0V (GND)
A	RS485 'A' from Fans
B	RS485 'B' from Fans
0V	Common 0V (GND)
+	Power supply +
Relay	Com Relay
	N/C Relay
A	RS485 'A' from 3 rd Party System e.g. BMS
B	RS485 'B' from 3 rd Party System e.g. BMS
0V	Common 0V (GND)

Table 4 – PCB Connector Identities and Pin Functions

Note: All "Power supply +" and "+24V" terminals are common (i.e. connected together)
All "0V" terminals are common (i.e. connected together)

Note: Do not connect anything to the 4-way plug-in "COM" connector or to the 5-way plug-in "I2C / SPI" and "PROGRAMMER" connectors.

Appendix C – Remote Monitoring & Control

By connecting the controller to a RS485 Modbus Master device (e.g. BMS) it is possible to remotely monitor and/or control the fan array or individual fans within an array. The controller response time to Modbus Master requests is 500ms for “locally stored” registers, and 1 second for “retrieved from fan” registers.

The Modbus Master device must have a minimum “Slave Response Timeout” of 1 second when polling “locally stored” registers, 2 seconds when polling “retrieved from fan” registers and 2 seconds when polling both.

The “retrieved from fan” registers are available in any operating mode, whereas in Modbus Relay Mode the “locally stored” fan registers will not be updated.

The supported Modbus Function Codes are: [03] Read Holding Register(s), [04] Read Input Register(s), [06] Write Single Holding Register and [16] Write Multiple Holding Registers.

⚠ IMPORTANT: Do not read/write more than 14 consecutive “locally stored” registers at a time, or more than 9 consecutive “retrieved from fan” registers at a time, otherwise a Modbus Exception Response will occur. See “Appendix D – Modbus Input Registers” and “Appendix E – Modbus Holding Registers for Configuration & Control” for more details

C.1 Remote Monitoring

Fans: Remote monitoring of individual fan parameters is achieved by connecting the controller’s Modbus Slave port to a Modbus Master device e.g., BMS and reading Modbus registers from either the controller’s locally stored holding registers or retrieved from fan registers.

The controller’s locally stored holding registers hold the same fan parameter values as those displayed on the LCD (power, RPM, temperatures, etc) for each connected fan. They are constantly being updated by the controller and the advantage of using them for monitoring is that, for example, the individual RPM of a fan is now available from a single “locally stored register” as opposed to reading and combining the values of two or more Modbus registers from the fan. See **Appendix F – Modbus Holding Registers for Individual Fan Monitoring** for more details. Please note that those registers are not updated when the controller is in “Modbus Relay” operating mode.

The “retrieved from fan” registers are useful when monitoring a fan parameter that is outside “locally stored register” parameters. It effectively allows the Modbus Master device to retrieve Modbus register values straight from the fan without interrupting the normal functions of the controller. See **Table 9 – Full Modbus Relay Register Map (retrieved from fan registers)** for more information. Those registers are always available and do not depend on a specific controller operating mode.

System: The monitoring of system parameters, such as total power consumption, total air volume or pressure, group alarms, etc is achieved by reading the controller’s Modbus input registers at addresses 1 to 6. See **Appendix D – Modbus Input Registers** for more details.

C.2 Remote Fan Array Control

Similar to remote monitoring, remote fan array control is also achieved by using the controller’s Modbus Slave port but it requires the controller to be set to one of the following operating modes: “Monitor & Control”, “Constant Volume /Pressure” or “Modbus Relay”. Depending on the operating mode, different Modbus holding registers must be used to control the speed of the fan array. For example, in “Monitor & Control”, use Fan Array Speed Control Holding Register. For “Constant Volume / Pressure” use both “Constant Volume/Pressure Setpoint High” and “Constant Volume/Pressure Setpoint Low” holding registers. See **Appendix E – Modbus Holding Registers for Configuration & Control** for more information.

210-OMI14229-Iss10	CN1116 Full OMI	Page 31 of 48
© ebm-papst UK Ltd 2025	Chelmsford Business Park Chelmsford Essex CM2 5EZ Telephone: +44(0)1245468555 Fax: +44(0)1245466336 e-mail sales@uk.ebmpapst.com	

C.3 Remote Speed Control – Individual Fans

To remotely control the speed of a single fan in the array, the controller must be first set to “Monitor & Control” operating mode and then to “Modbus Relay” operating mode. Please see **Appendix G – Example of Modbus Relay Operation** for more information.

Appendix D – Modbus Input Registers

The purpose of the registers below is for remote monitoring of the fan array status and system statuses such as total power consumption and total volume or pressure.

Locally Stored Input Registers		
ADDR (hex)	DESCRIPTION	DETAILS
0	TOTAL FANS	NUMBER OF FANS ADDRESSED AND CONNECTED TO THE CONTROLLER
1	FANS WITH ALARMS	NUMBER OF FANS DISPLAYING ONE OR MORE ALARM CONDITION
2	FANS WITH NO COMMS	NUMBER OF FANS NOT RESPONDING TO MODBUS MESSAGES FROM THE CONTROLLER
3	FANS WITH WARNINGS	NUMBER OF FANS DISPLAYING ONE OR MORE WARNING CONDITIONS
4	NUMBER OF FAILED SENSORS	NUMBER OF FAILED SENSORS (APPLICABLE ONLY WHEN USING ONE OR MORE SENSORS AT “FAN SENSOR INPUT”)
5	FAN ARRAY SPEED SETPOINT	FAN ARRAY SPEED SETPOINT (0-100%)
6	TOTAL POWER CONSUMPTION HIGH BYTES	THE HIGHER 16-BITS OF A 32-BIT UNSIGNED INTEGER REPRESENTING THE TOTAL POWER CONSUMPTION OF THE FAN ARRAY (W)
7	TOTAL POWER CONSUMPTION LOW BYTES	THE LOWER 16-BITS OF A 32-BIT UNSIGNED INTEGER REPRESENTING THE TOTAL POWER CONSUMPTION OF THE FAN ARRAY (W)
8	CONSTANT VOLUME/PRESSURE SETPOINT HIGH BYTES	THE HIGHER 16-BITS OF A 32-BIT UNSIGNED INTEGER REPRESENTING THE CONSTANT VOLUME/PRESSURE SETPOINT (0-65535) *
9	CONSTANT VOLUME/PRESSURE SETPOINT LOW BYTES	THE LOWER 16-BITS OF A 32-BIT UNSIGNED INTEGER REPRESENTING THE CONSTANT VOLUME/PRESSURE SETPOINT (0-65535) *
A	TOTAL VOLUME/PRESSURE HIGH BYTES	THE HIGHER 16-BITS OF A 32-BIT UNSIGNED INTEGER REPRESENTING THE SENSOR READING IN m3/h, CFM, Pa or INWG (0-65535) *
B	TOTAL VOLUME/PRESSURE LOW BYTES	THE LOWER 16-BITS OF A 32-BIT UNSIGNED INTEGER REPRESENTING THE SENSOR READING IN m3/h, CFM, Pa or INWG (0-65535) *
C	CONTROLLER UPTIME HIGH BYTES	THE HIGHER 16-BITS OF A 32-BIT UNSIGNED INTEGER REPRESENTING THE CONTROLLER UPTIME COUNTER (IN SECONDS)
D	CONTROLLER UPTIME LOW BYTES	THE LOWER 16-BITS OF A 32-BIT UNSIGNED INTEGER REPRESENTING THE CONTROLLER UPTIME COUNTER (IN SECONDS)

Table 5 - Modbus Input Registers

* If “Unit Type = Pressure” and “Measurement Unit = Imperial” then the value is presented as (INWG x 1000)

⚠ NOTE: Do not to read/write more than 14 consecutive registers at a time, otherwise a Modbus Exception Response will occur

Appendix E – Modbus Holding Registers for Configuration & Control

The values changed here are saved in non-volatile memory unless stated otherwise.

ADDR (hex)	DESCRIPTION (Locally Stored Registers)
0	Operating Mode
1	Save Modbus Control Speed Setpoint – 10,000 total write cycle limit (See <i>Caution on the next page</i>)
2	Controller's 0-10V Input Control Mode Enable/Disable
3	Keypad Control Mode Enable/Disable
4	Fan Array Set Speed Register
5	Menu Lock Enable/Disable
6	Fan Array Custom RPM Limit
7	Fan Array Maximum RPM Limit
8	Alarm Output Mode
9	Volume/Pressure Alarm Enable/Disable
A	Volume/Pressure Alarm Threshold
B	External Pressure Sensor Monitoring Enable/Disable
C	Constant System Type (Pressure or Volume)
D	Measurement Unit (Metric or Imperial)
E	Sensor Type (50Pa, 200Pa, 500Pa, 1000Pa, 2000Pa or 3500Pa)
F	Fan k-Factor
10	Target Volume/Pressure Setpoint High *
11	Target Volume/Pressure Setpoint Low *
12	PID P Value
13	PID I Value
14	PID D Value
15	Sensor Input (Controller or Fan)
16	Sensor Reading Method (Average, Minimum, Maximum or Sum) **
17	Number of Sensors

Table 6 – Controller's Dedicated Modbus Holding Registers Part 1

* (1) The Target Volume/Pressure is a 32-bit unsigned integer: the high value represents the higher 16-bits and the low value represents the lower 16-bits (2) For a Constant Pressure system whose measurement unit is set to IMPERIAL, the target pressure setpoint entered here will be the pressure in inch of water times 1000 e.g. for a setpoint of 4.018 inch of water, write 0 to the HIGH register and 4018 to the LOW register.

** Only applicable when using more than one sensor. The total volume/pressure of the system will be derived according to the reading method specified on this register.

⚠ NOTE: Do not to read/write more than 14 consecutive registers at a time, otherwise a Modbus Exception Response will occur

Operating Mode – sets the controller’s operating mode

Address (Hex): 0

Availability: All operating modes

Values: 0=Monitor (default) / 1=Monitor & Control / 2=Constant Volume/Constant Pressure / 3=Transparent Mode

Save Modbus Control Speed Setpoint – enables the latest change at the fan array set speed holding register to be saved in the controller’s non-volatile memory

Address (Hex): 1

Availability: Monitor & Control Mode

Values: 0=OFF (default) / 1=ON

⚠ CAUTION: The “Save Modbus Control Speed Setpoint” register must not be activated if the “Fan Array Set Speed” register is repeatedly write accessed at frequent intervals:

If this instruction is not observed, there is a risk the controller’s memory will be permanently destroyed.

If this function is activated, the maximum number of times “Fan Array Set Speed” can be write accessed over the entire service life of the controller is 10,000.

Controller’s 0-10V Input Control Mode – allows the fan array to be controlled via a 0-10V signal fed to the controller’s 0-10V input

Address (Hex): 2

Availability: Monitor & Control Mode

Values: 0=OFF / 1=ON (default)

Keypad Control Mode– allows the fan array to be speed controlled using the Controller’s keypad

Address (Hex): 3

Availability: Monitor & Control Mode

Values: 0=OFF (default) / 1=ON

Fan Array Set Speed Register – sets the speed of the fan array

Address (Hex): 4

Availability: Monitor & Control Mode

Values: 0 to 100 (%)

NOTE: The value changed here is not saved in non-volatile memory unless “Save Modbus Control Speed Setpoint” is set to 1

Menu Lock – Enables menu lock from fan status screen

Address (Hex): 5

Availability: All Operating Modes

Values: 0=OFF (default) / 1=ON

Fan Array Custom RPM Limit – sets the RPM limit of all fans to this value

Address (Hex): 6

Availability: Monitor, Monitor & Control Modes

Values: 0 to Max RPM (see fan datasheet) – values set too high will be capped by the fan’s maximum permissible RPM limit

Fan Array Maximum RPM Limit – automatically set each fan to its maximum RPM limit

Address (Hex): 7

Availability: Monitor, Monitor & Control Modes

Values: 0=OFF / 1=ON (returns to 0 after command completes)

Alarm Output Mode – type of faults that cause the controller’s alarm output relay to open

Address (Hex): 8

Availability: Monitor, Monitor & Control, Constant Volume, Constant Pressure Modes

Values: 0 = Fan Alarms / 1 = Fan Warnings / 2 = Fan Alarms & Fan Warnings / 3 = Relay Disabled (Default)

Volume/Pressure Alarm – triggers an alarm when readings are above the threshold

Address (Hex): 9

Availability: Monitor Only, Monitor & Control, Constant Volume, Constant Pressure Modes

Values: 0=OFF (default) / 1=ON

NOTES: For Constant Volume/Pressure operating modes an alarm will be generated whenever the fan array reaches 100% speed and is not able to reach the target pressure/volume setpoint.

Volume/Pressure Alarm Threshold – related to the volume/pressure alarms (see above)

Address (Hex): A

Availability: Monitor, Monitor & Control Modes

Values: 0 to 100 (%). Default is 50.

NOTE: For Constant Volume/Pressure operating modes, the value of this register is fixed to 100

External Pressure Sensor Monitoring – enables/disables the monitoring of a 0-10V pressure sensor

Address (Hex): B

Availability: Monitor, Monitor & Control Modes

Values: 0=OFF (default) / 1=ON

Constant System Type – sets the system type to volume or pressure

Address (Hex): C

Availability: Monitor, Monitor & Control, Constant Volume, Constant Pressure Modes

Values: 0=Volume (default) / 1=Pressure

Measurement Unit – sets the measurement unit for display and/or control purposes

Address (Hex): D

Availability: Monitor, Monitor & Control, Constant Volume, Constant Pressure Modes

Values: 0 (default) Metric / 1= Imperial (if imperial volume then CFM, if imperial pressure then i.n.w.g)

Sensor Type – the type of pressure sensor attached to the controller or the fans

210-OMI14229-Iss10	CN1116 Full OMI	Page 35 of 48
© ebm-papst UK Ltd 2025	Chelmsford Business Park Chelmsford Essex CM2 5EZ Telephone: +44(0)1245468555 Fax: +44(0)1245466336 e-mail sales@uk.ebmpapst.com	

Address (Hex): E

Availability: Monitor, Monitor & Control, Constant Volume, Constant Pressure Modes
Values: 0=50Pa (default) / 1=200Pa / 2=500Pa / 3=1000Pa / 4=2000Pa / 5=3500Pa

Fan k-Factor – the fan k-Factor used for volume monitoring or constant volume operation**Address (Hex): F**

Availability: Monitor, Monitor & Control, Constant Volume, Constant Pressure Modes
Values: 0 (default) to 1200

Target Volume/Pressure (Higher 16-bits of a 32-bit unsigned integer) – first part of the setpoint used to maintain a constant volume/pressure

Availability: Constant Volume, Constant Pressure Modes
Minimum value = 0 Maximum Value: 65535

Target Volume/Pressure (Lower 16-bits of a 32-bit unsigned integer) – second part of the setpoint used to maintain a constant volume/pressure**Address (Hex): 11**

Availability: Constant Volume, Constant Pressure Modes
Minimum value = 0 Maximum Value: 65535

PID P-Value – sets the proportional value of the controller's PID algorithm**Address (Hex): 12**

Availability: Constant Volume, Constant Pressure Modes
Values: 0 to 1000 (default = 15)

PID I-Value – sets the integral value of the controller's PID control algorithm**Address (Hex): 13**

Availability: Constant Volume, Constant Pressure Modes
Values: 0 to 1000 (default = 30)

PID D-Value – sets the derivative value of the controller's PID control algorithm**Address (Hex): 14**

Availability: Constant Volume, Constant Pressure Modes
Values: 0 to 1000 (default = 0)

Sensor Input – sets where the controller looks for a pressure sensor reading**Address (Hex): 15**

Availability: Monitor and Control / Constant Volume / Constant Pressure Modes
Values: 0 = Controller (default) / 1 = Fan

Sensor Reading Method – sets how the total pressure/volume is derived when operating with multiple pressure sensors**Address (Hex): 16**

Availability: Monitor & Control Modes (Sensor Monitor Enabled, Fan Sensor Input), Constant Volume, Constant Pressure Modes (Fan Sensor Input)
Values: 0 = Average (default for Pressure) / 1 = Minimum / 2 = Maximum / 3 = Sum (default for Volume, not available for Pressure)

Number of Sensors – the number of pressure sensors in the system

210-OMI14229-Iss10	CN1116 Full OMI	Page 36 of 48
© ebm-papst UK Ltd 2025	Chelmsford Business Park Chelmsford Essex CM2 5EZ Telephone: +44(0)1245468555 Fax: +44(0)1245466336 e-mail sales@uk.ebmpapst.com	

Address (Hex): 17

Availability: Monitor and Control / Constant Volume / Constant Pressure Modes

Values: 1 to 100

Appendix F – Modbus Holding Registers for Individual Fan Monitoring

These Modbus registers contain the same individual fan parameter values as shown on the LCD display. A “2 Fan Array” is used as an example in the table below. This set of registers scales up and down depending on the total connected fans:

Parameter Nº	ADDR (hex)	DESCRIPTION (Locally Stored Registers)
Parameter 1	CB00	FAN 1 - FAN STATUS (0= No Comms, 1= Healthy, 2= Alarm, 3= Warning)
	CB01	FAN 2 - FAN STATUS (0= No Comms, 1= Healthy, 2= Alarm, 3= Warning)
Parameter 2	CB02	FAN 1 – ALARM REGISTER *
	CB03	FAN 2 – ALARM REGISTER *
Parameter 3	CB04	FAN 1 – WARNING REGISTER *
	CB05	FAN 2 – WARNING REGISTER *
Parameter 4	CB06	FAN 1 - POWER (W)
	CB07	FAN 2 - POWER (W)
Parameter 5	CB08	FAN 1 - SPEED (RPM)
	CB09	FAN 2 - SPEED (RPM)
Parameter 6	CB0A	FAN 1 - RPM LIMIT (RPM)
	CB0B	FAN 2 - RPM LIMIT (RPM)
Parameter 7	CB0C	FAN 1 - MOTOR TEMPERATURE (°C)
	CB0D	FAN 2 - MOTOR TEMPERATURE (°C)
Parameter 8	CB0E	FAN 1 - ELECTRONICS TEMPERATURE (°C)
	CB0F	FAN 2 - ELECTRONICS TEMPERATURE (°C)
Parameter 9	CB10	FAN 1 - HOURS RUN (hours)
	CB11	FAN 2 - HOURS RUN (hours)
Parameter 10	CB12	FAN 1 – SPEED SETPOINT (0-100%)
	CB13	FAN 2 – SPEED SETPOINT (0-100%)
Parameter 11	CB14	FAN 1 - SENSOR READING HIGH (0-65535) **
	CB15	FAN 1 - SENSOR READING LOW (0-65535) **
	CB16	FAN 2 - SENSOR READING HIGH (0-65535) **
	CB17	FAN 2 - SENSOR READING LOW (0-65535) **

Table 7 – Controller’s Dedicated Modbus Holding Registers Part 2

* See Table 9 below for information about the fan alarm and fan warning registers

** Parameter 11 is the “Sensor Reading” which is a 32-bit value comprised of two 16-bit (high and low) values. This parameter is only available when using the fan as a sensor input

For parameters 1 to 10, the equation below can be used to derive the Modbus Address (in decimal):

$$\text{Modbus Address} = 51967 + (\text{Parameter Number} * \text{Total Fans}) - (\text{Total Fans} - \text{Fan Number})$$

For parameter 11, the following equations can be used to derive the Modbus Address (in decimal) of the high and low components for each fan:

$$\text{Modbus Address Sensor Reading High} = 51967 + (10 * \text{Total Fans}) + (\text{Fan Number} * 2) - 1$$

$$\text{Modbus Address Sensor Reading Low} = 51967 + (10 * \text{Total Fans}) + (\text{Fan Number} * 2)$$

⚠ NOTE: Do not to read/write more than 14 consecutive registers at a time, otherwise a Modbus Exception Response will occur.

FAN ALARM REGISTER

Coding:

MSB	0	0	0	UzLow	0	RL_Cal	0	n_Limit
-----	---	---	---	-------	---	--------	---	---------

LSB	BLK	HLL	TFM	FB	SKF	TFE	0	PHA
-----	-----	-----	-----	----	-----	-----	---	-----

If a bit is set, the error described below has occurred:

- UzLow: DC-link undervoltage
- RL_Cal: Rotor position sensor calibration error
- n_Limit: Speed limit exceeded

- BLK: Motor blocked
- HLL: Hall sensor error
- TFM: Motor overheating
- FB: Fan Bad (general error)
- SKF: Communication error between master controller and slave controller
- TFE: Output stage overheating
- PHA: Phase failure (3-phase devices) or line undervoltage (single-phase devices)

FAN WARNING REGISTER

Coding:

The setting of a bit activates the warning:

MSB	LRF	UeHigh	0	UzHigh	Heating	Cable break	n_Low	Reserved
-----	-----	--------	---	--------	---------	-------------	-------	----------

LSB	Brake	UzLow	TEI_high	TM_high	TE_high	P_Limit	L_high	I_Limit
-----	-------	-------	----------	---------	---------	---------	--------	---------

- LRF : Shedding function active
- UeHigh : Line voltage high
- UzHigh : DC-link voltage high
- Heating : Heating activated
The motor should not be started when the heating is activated!
- Cable break : cable break at analog input or PWM input for the analogue set valueinput (voltage at analog input < value for cable break voltage- or signal at PWM input statically high)
- n_Low : Actual speed is less than the speed limit set for speed monitoring
- RL_Cal : Calibration of rotor position sensor in progress
- Brake : Brake operation: triggered in instances where an external force causes the fan/motor to run in the wrong direction at high speed for a prolonged period of time so the motor is unable to start properly

- UzLow : DC-link voltage low
- TEI_high : Temperature inside electronics high
- TM_high : Motor temperature high
- TE_high : Output stage temperature high
- P_Limit : Power limiter currently engaged
- L_high : Line impedance too high (DC-link voltage unstable)
- I_Limit : Current limitation currently engaged

Appendix G – Example of Modbus Relay Operation

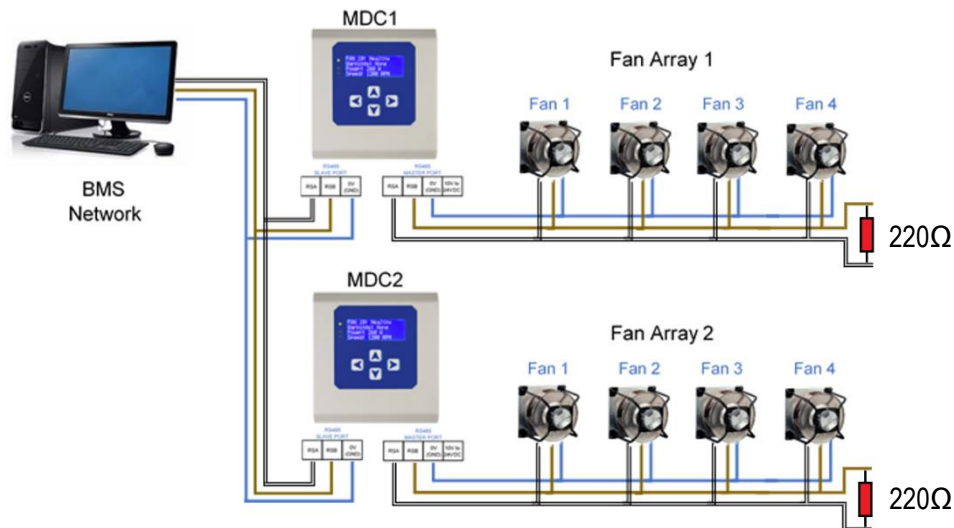

Initial Configuration Steps

- BMS Network has slave addresses 1 and 2 available i.e., not taken by any other device
- Both MDCs have successfully addressed all their respective fans
- Both MDCs have changed their operating mode to “Monitor & Control” (the control mode is not important)
 - See **H8 – Operation Mode - Monitor & Control**
 - This step is purely taken to set all fans to “Modbus” speed control as opposed to their factory settings of “Analogue 0-10V” speed control
- MDC1 Modbus Slave address is kept at its factory setting value of “1”
- MDC2 Modbus Slave address has been changed to “2”, see **H20 – Advanced Settings – BMS Settings**
- Both MDCs have changed their operating mode to “Modbus Relay”, see **H11 – Operation Mode - Modbus Relay**

Example of setting the speed of Fan 4 (at Fan Array 1) to 100%: BMS writes “65535” to Holding Register Address 801 (hex) of MDC1 (Modbus Slave Address 1). This is Holding Register D001 of Fan 4 of MDC1.

Example of reading the Motor Status Register of Fan 3 (at Fan Array 2): BMS reads input register address 40B (hex) of MDC 2 (Modbus Slave Address 2). This is Input Register D011 of Fan 3 of MDC2.

NOTE 1: Do not to read/write more than 9 consecutive “retrieved from fan” registers at a time, otherwise a Modbus Exception Response will occur.

Operating and Maintenance Instructions

⚠ NOTE 2: The controller will respond to the BMS after the communication with the fan has completed. A Modbus Exception Response will be returned to the BMS if the read/write to the fan has failed or the fan has no comms.

Starting Modbus Address per Fan

Fan	Starting Address (Hex)	Fan	Starting Address (Hex)	Fan	Starting Address (Hex)	Fan	Starting Address (Hex)
1	200	26	3400	51	6600	76	9800
2	400	27	3600	52	6800	77	9A00
3	600	28	3800	53	6A00	78	9C00
4	800	29	3A00	54	6C00	79	9E00
5	A00	30	3C00	55	6E00	80	A000
6	C00	31	3E00	56	7000	81	A200
7	E00	32	4000	57	7200	82	A400
8	1000	33	4200	58	7400	83	A600
9	1200	34	4400	59	7600	84	A800
10	1400	35	4600	60	7800	85	AA00
11	1600	36	4800	61	7A00	86	AC00
12	1800	37	4A00	62	7C00	87	AE00
13	1A00	38	4C00	63	7E00	88	B000
14	1C00	39	4E00	64	8000	89	B200
15	1E00	40	5000	65	8200	90	B400
16	2000	41	5200	66	8400	91	B600
17	2200	42	5400	67	8600	92	B800
18	2400	43	5600	68	8800	93	BA00
19	2600	44	5800	69	8A00	94	BC00
20	2800	45	5A00	70	8C00	95	BE00
21	2A00	46	5C00	71	8E00	96	C000
22	2C00	47	5E00	72	9000	97	C200
23	2E00	48	6000	73	9200	98	C400
24	3000	49	6200	74	9400	99	C600
25	3200	50	6400	75	9600	100	C800

Table 9 – Full Modbus Relay Register Map (retrieved from fan registers)

The controller re-maps all individual fan Modbus registers to register addresses at the controller's network address. Example: fan 1 holding register D000 becomes the controller's holding register 200 (hex), fan 2 holding register D000 is the controller's holding register 400 (hex) and so on.

The fan register contents are not stored at the controller: when a controller's fan register is accessed, it triggers a read/write of data to/from the fan. The data is then passed on by the controller to the BMS.

Appendix H – Menu Structure Flow Chart

H1 – Fan Addressing - New Fan Array -Initial Setup

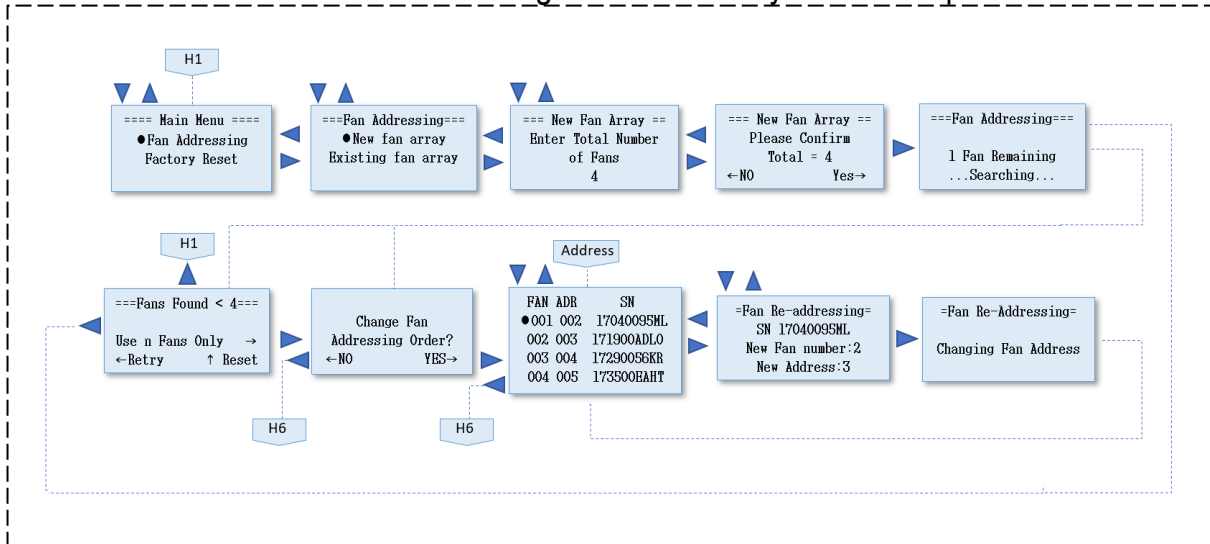

H2 – Fan Addressing - Existing Fan Array - Initial Setup

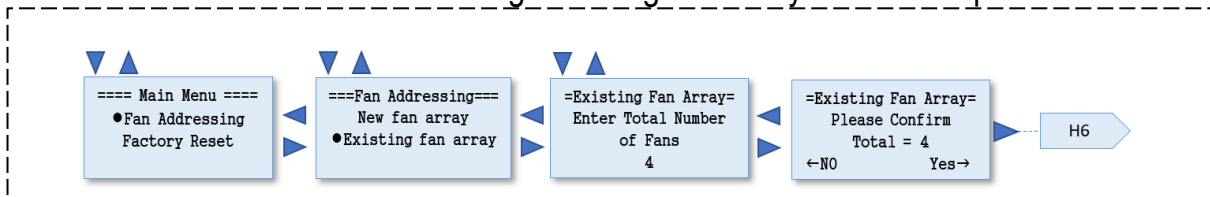

H3 – Initial Factory Reset

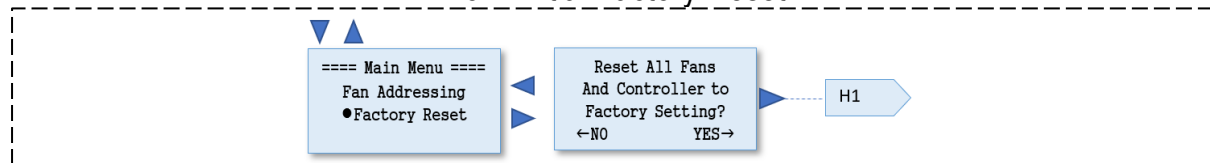

H4 – Fan Replacement

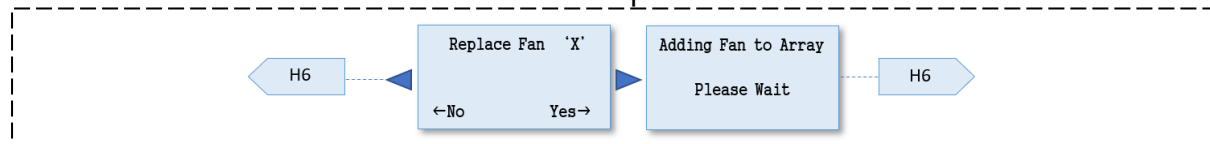

H5 – Main Menu

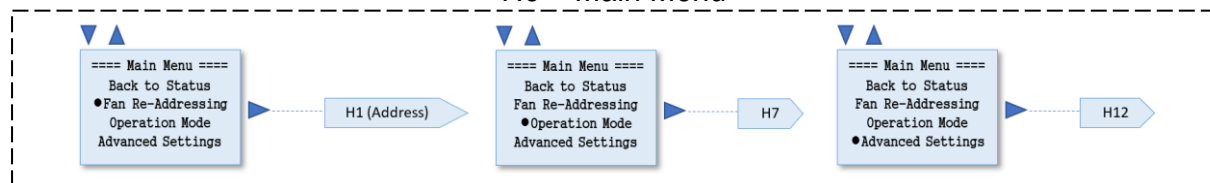

H6 – Fan Status

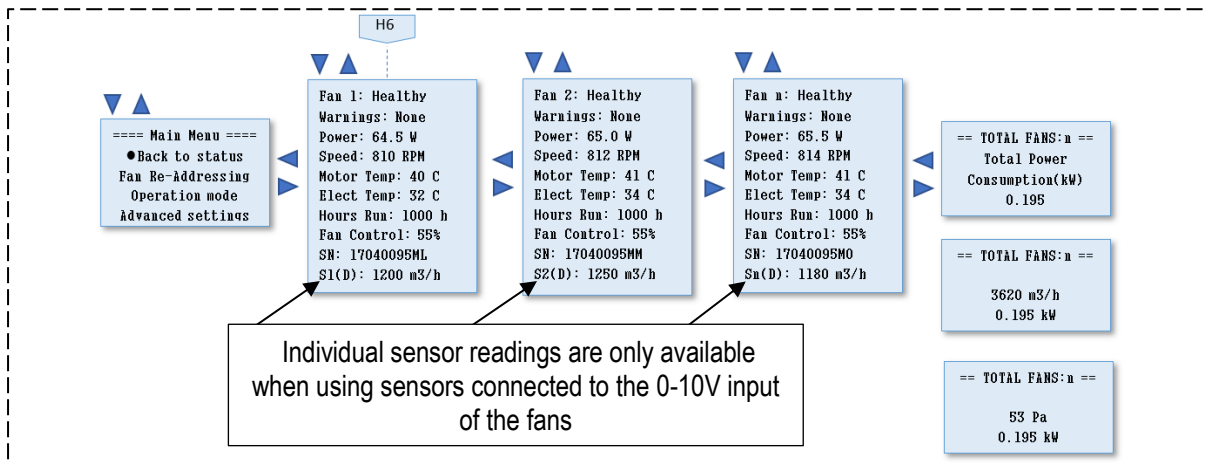

H7 – Operation Mode – Monitor

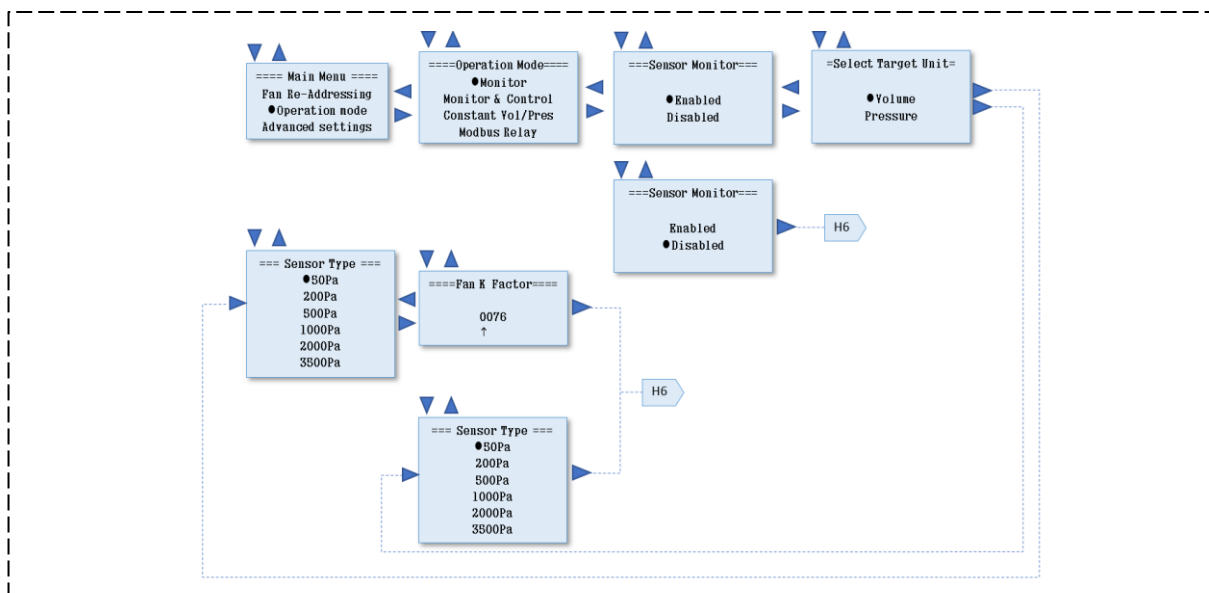

H8 – Operation Mode - Monitor & Control

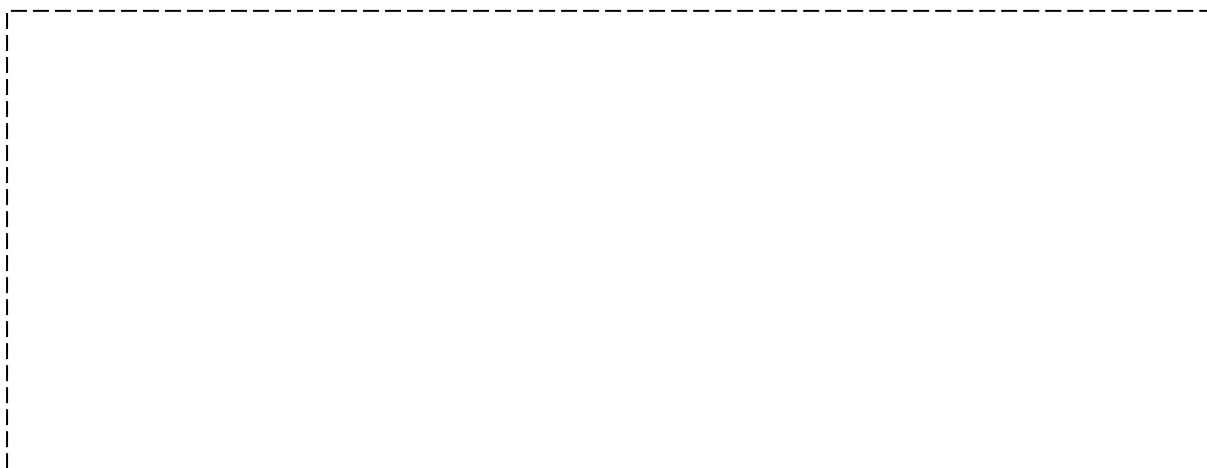

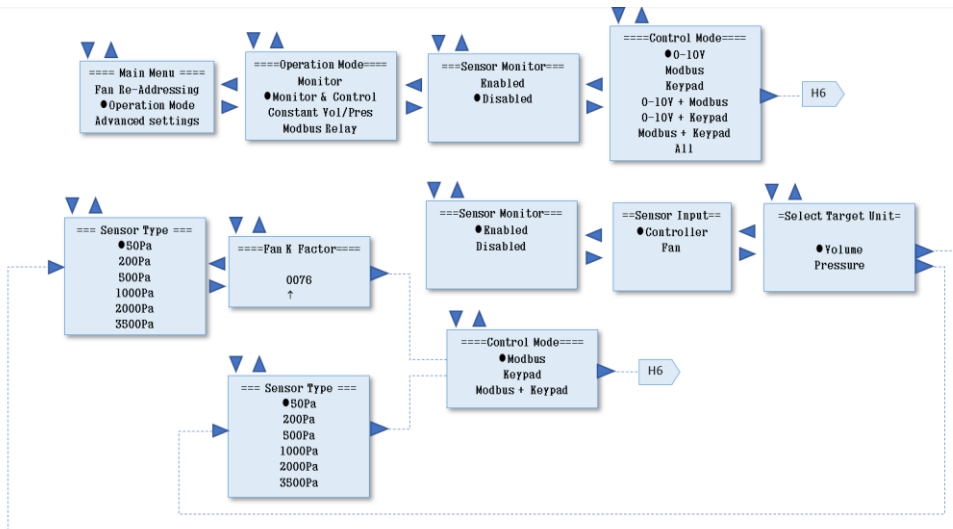

H9 – Operation Mode - Monitor & Control – Keypad Control

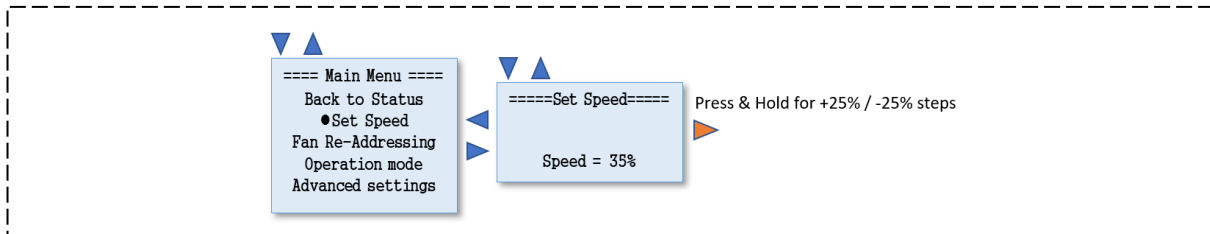

H10 – Operation Mode - Constant Volume / Constant Pressure



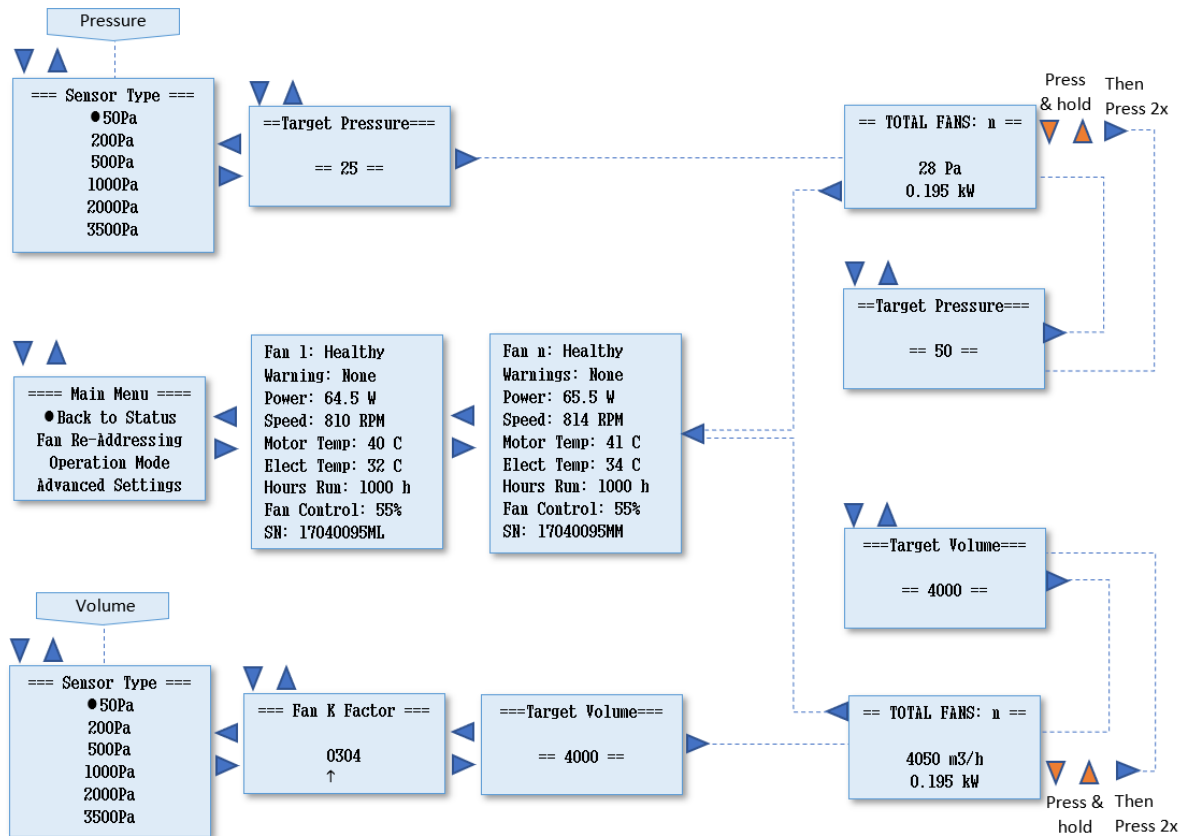

H11 – Operation Mode - Modbus Relay

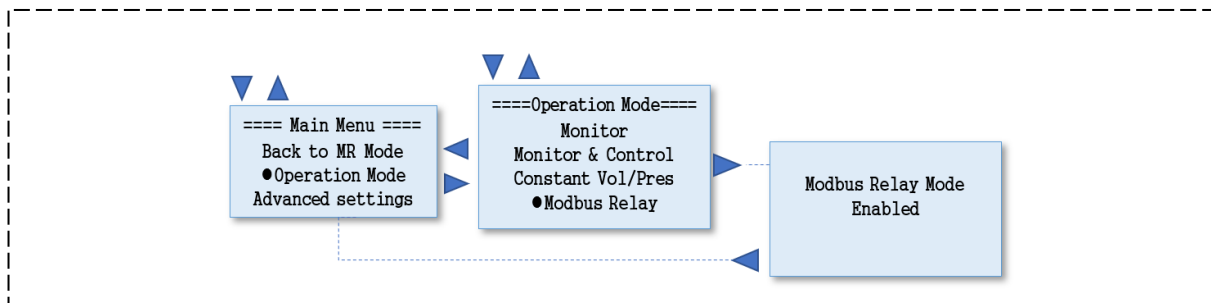

H12 – Advanced Settings Sub Menu

Not all sub-menus inside “Advanced Settings” will be available at once. It depends on the operating mode, and other key configurations. The order shown here is not necessarily the order that appears on the screen.

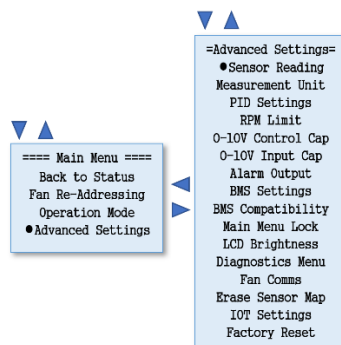

H13 – Adv. Settings - Sensor Reading

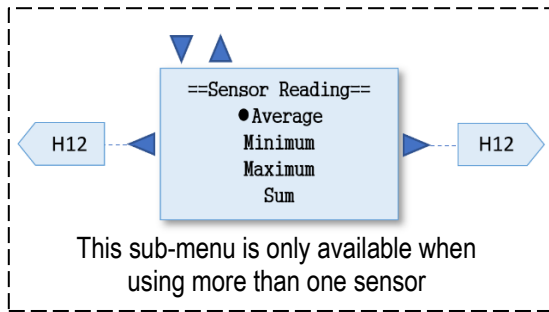

H14 – Adv. Settings – Measurement Unit

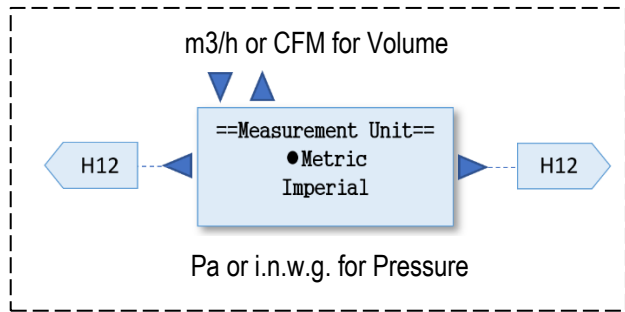

H15 – Advanced Settings – PID Settings

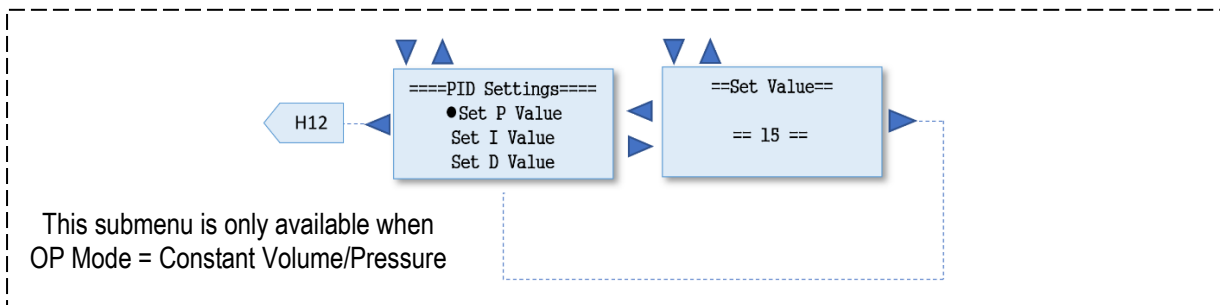

H16 – Advanced Settings – RPM Limit

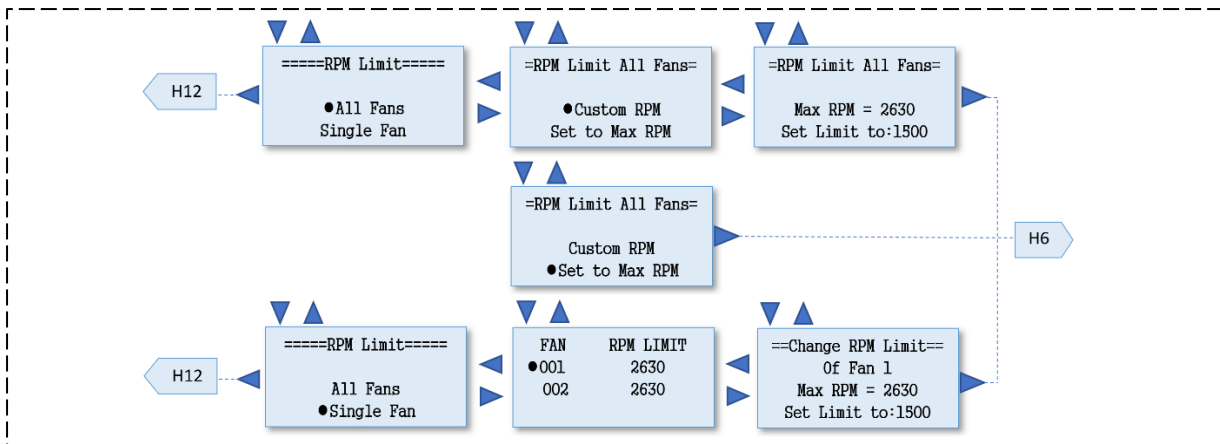

H17 – Adv. Settings – 0-10V Control Cap

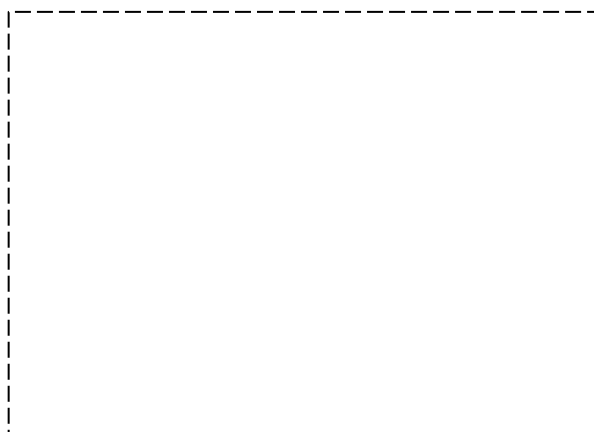

H18 – Adv. Settings – 0-10V Input Cap



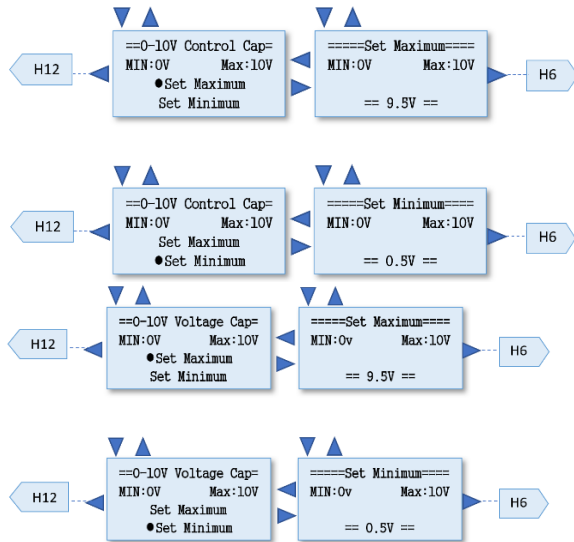

This submenu is only available when
OP Mode = Monitor

This submenu is only available when
OP Mode = Monitor & Control and the
control mode includes the "0-10V Input" option

H19 – Advanced Settings – Alarm Output

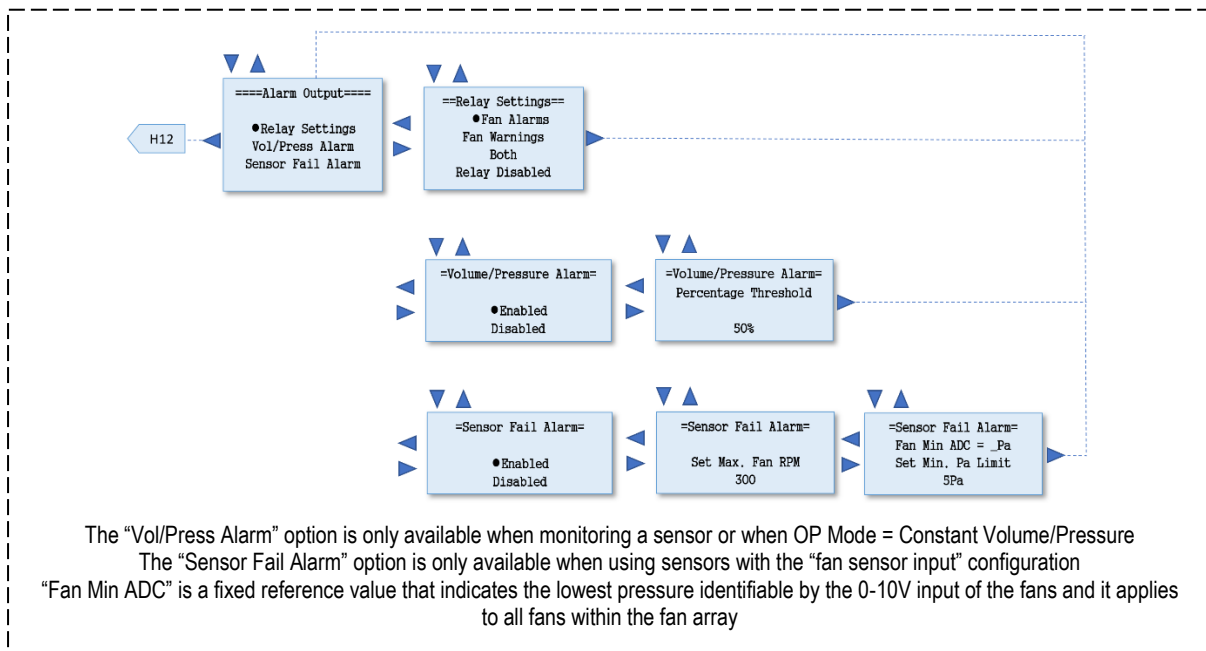

H20 – Advanced Settings – BMS Settings

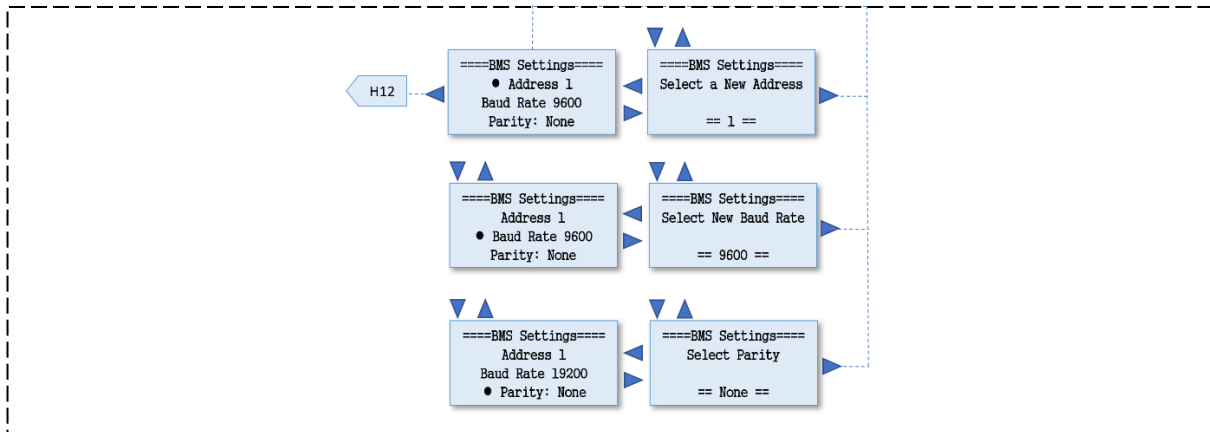

H21 – Advanced Settings – BMS Compatibility

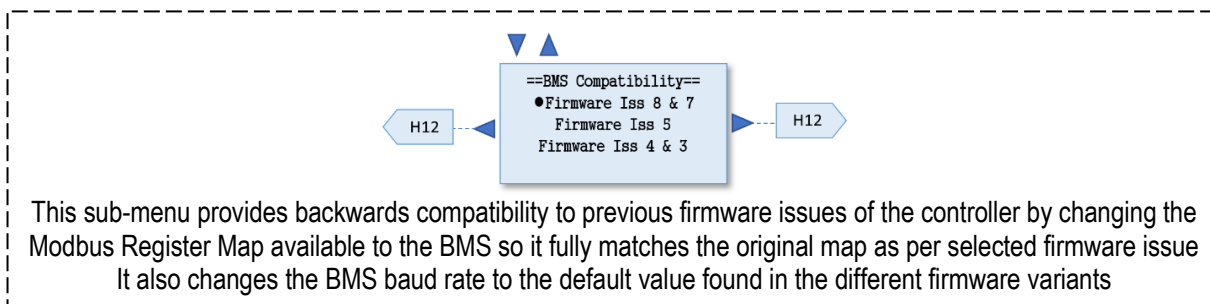

H22 – Advanced Settings – Main Menu Lock

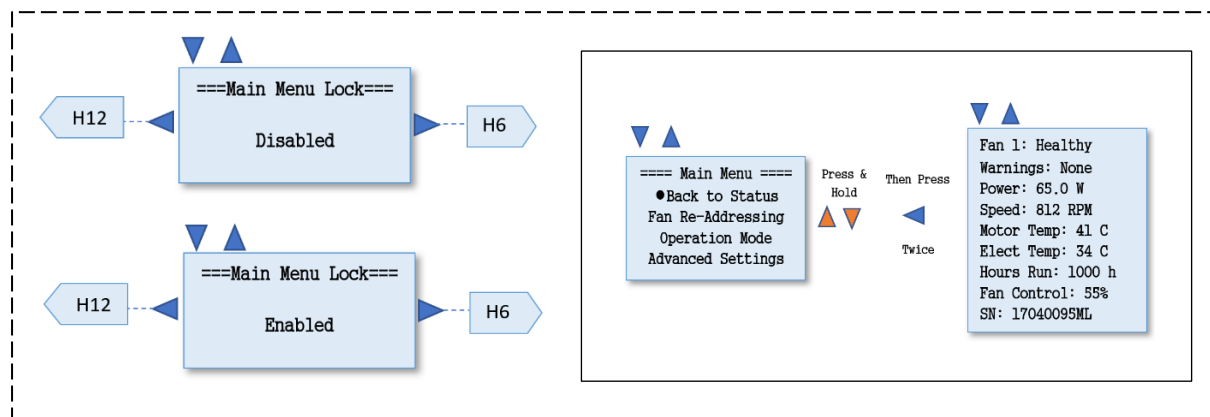

H23 – Diagnostics Menu

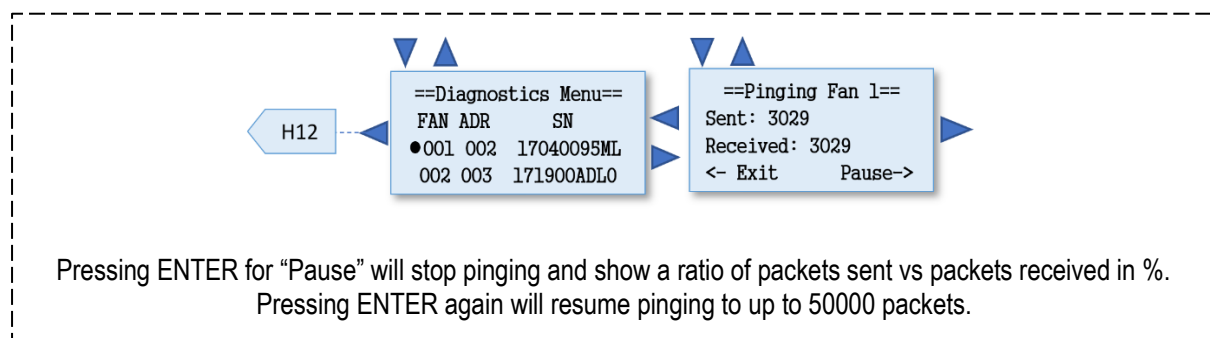

H24 – Fan Comms

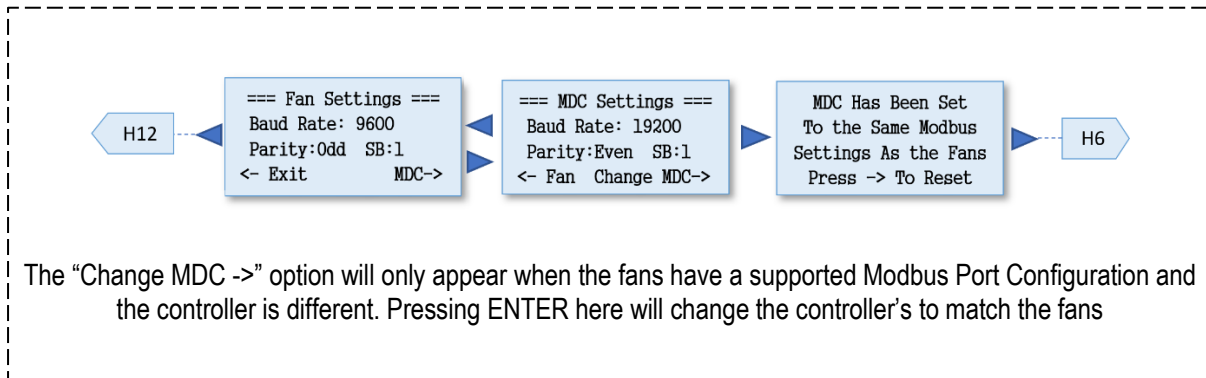

H25 – Adv. Settings – LCD Brightness

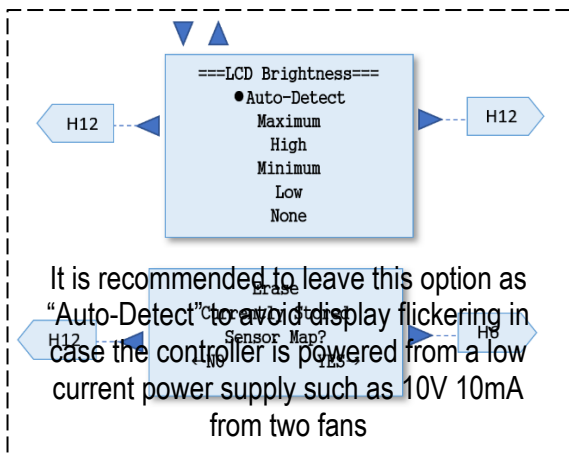

H26 – Adv. Settings – Erase Sensor Map

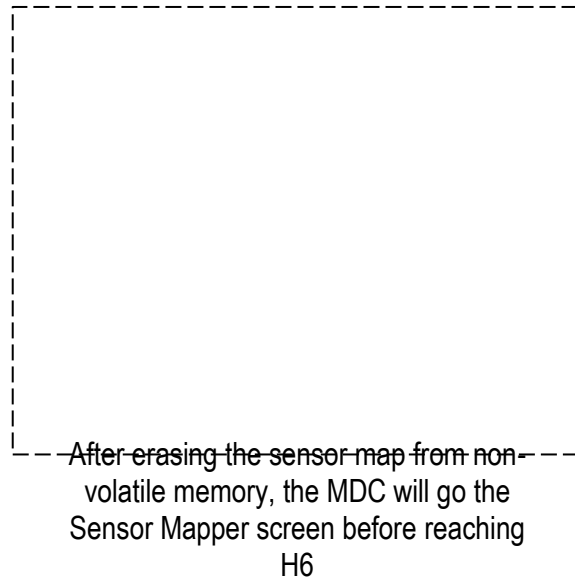

H27 – Advanced Settings – Factory Reset

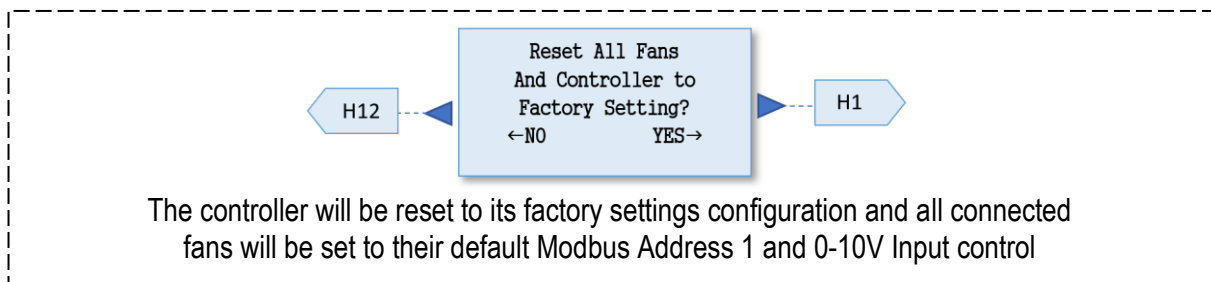

www.ebmpapst.com

ebmpapst

engineering a better life

ebm papst UK
Chelmsford Business Park,
CM2 5EZ, United Kingdom
+44 (0) 1245 456530
info@uk.ebmpapst.com